

SANUPS A11N

Online UPS

Ver. 3
English



SANUPS A11N

Suitable for servers, base stations, and factory facilities



UPS unit
3-year
warranty

High Efficiency

- This UPS achieves a conversion efficiency of 94% (up to 95.1%).⁽¹⁾

High Reliability

- Output capacity can be expanded to up to 20 kVA by combining up to four 5 kVA units. The parallel redundant operation⁽²⁾ allows one unit to be used as a spare unit, delivering a highly reliable and stable power supply to loads.
- The UPS performs battery self-tests automatically at regular intervals, preventing malfunction due to battery run-out in the event of a power failure. Battery testing requires no power interruption to loads.

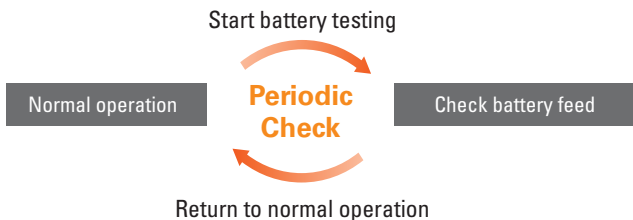

Note: Battery test interval can be set by the user.

Space-Saving

- The compact 3U-sized⁽¹⁾ UPS unit is suitable for standard EIA/JIS 19-inch racks.

Scalable capacity

Power distribution unit



Parallel operation (N configuration)	5 kVA / 4.5 kW	10 kVA / 9 kW	15 kVA / 13.5 kW	20 kVA / 18 kW
Parallel redundant operation (N+1 configuration)	-	5 kVA / 4.5 kW	10 kVA / 9 kW	15 kVA / 13.5 kW

Easy Maintenance

- Models with built-in maintenance bypass circuit can continue to supply grid power during maintenance. During parallel redundant operation,⁽²⁾ in particular, inverter power can be continued while replacing UPS units even if an outage occurs during maintenance.

Note: The maintenance bypass circuit is not available for UL/CE certified models.

For Use as an Emergency Battery

- This UPS features battery cold start function⁽³⁾ that enables the UPS unit to start up on and power loads from battery even without grid AC power.

Compatible with High Power Factor Loads

- With a 0.9 load power factor, the UPS is capable of providing its power to loads with a high power factor such as servers.

Output capacity of **5 kVA** → **4.5 kW max.**

Output capacity of **20 kVA** → **18 kW max.**

(1) For a single unit of a 5-minute backup model with 5 kVA output capacity.

(2) Parallel redundant operation is an operation in which the UPS output capacity has a sufficient margin for the load. The S-A11N103A005T can perform the redundant operation for a 5 kVA load.

(3) This function is selectable at the time of order. Note that it is not available with UL/CE certified models.

Installation examples



Mountable in an EIA standard 19-inch rack
 Rack support rails are optional.



Vertical

You can change the orientation of the LCD panel.
 Floor mounting brackets are included as standard for the single unit type (shown in the photo) and optional for types with a PDU.

Views and Part Names

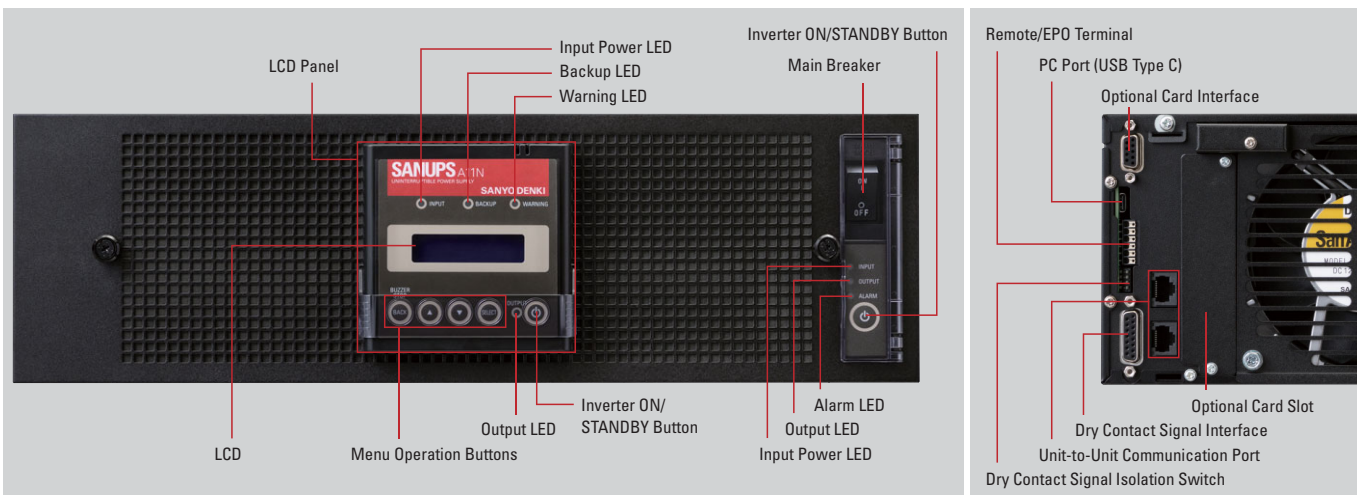

Front View - Operating Panel

Rear View - Communication Interface

Note: The photos (5-minute backup model shown above) may look different from the actual products in the printed text, etc.

Load Level vs Backup Time

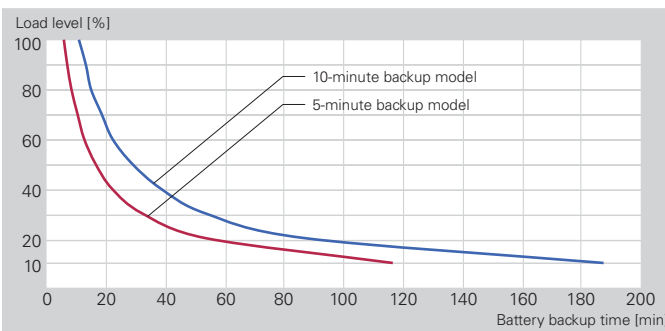

Note: At a 25°C ambient temperature and load power factor of 0.9 for a 5-minute backup model and 0.8 for a 10-minute backup model, using new, fully charged batteries.

SANUPS SOFTWARE STANDALONE

A free software program (Windows version) that enables the power management from computers is available for download from our website.

UPS status can be checked at a glance from a PC or server.
 This software can only be used on computers in serial connection with UPS.
 For power management via a network, we have optional network solutions available.

Main functions

- Automatic start-up/shutdown of computers
- Scheduled operation
- UPS status display
- Message display
- UPS event log

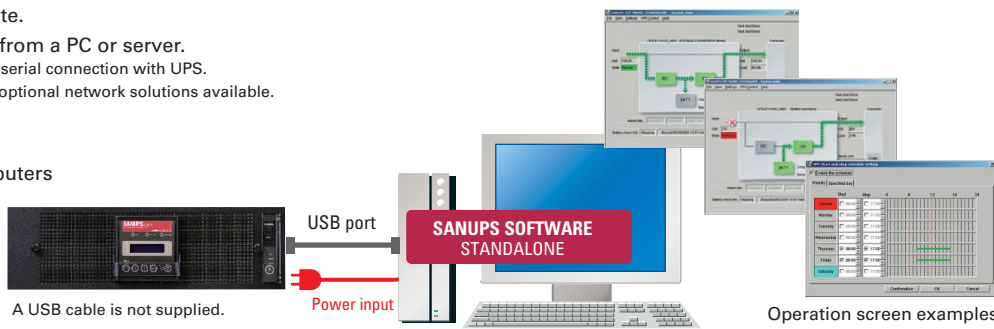

Lineup Input and output connector types are indicated by the following icons: **T** Terminal block, **P** Plug, **C** Outlet

[No. of phases/wires] Input voltage	[No. of phases/wires] Output voltage	Output capacity		Scalability (Max. 20 kVA) ⁽¹⁾	Input connector	Output connector	Safety Standards	Free- standing	Rack mount	Battery backup time ⁽²⁾ (min)	Order no. ⁽³⁾	Page	
		[kVA]	[kW]									Specifications	Dimensions
[Single-phase 2-wire] 200 V 200/208/220/ 230/240 V	[Single-phase 2-wire] 200 V 200/208/220/ 230/240 V	5	4.5	—	T	T C	—	✓	✓	5	S-A11N502A005T	p. 6	p. 12
										10	S-A11N502A010T	p. 6	p. 13
										30	S-A11N502A030T	p. 6	p. 20
										60	S-A11N502A060T	p. 6	p. 20
										180	S-A11N502A180T	p. 6	p. 20
										15	S-A11N502A015T	p. 6	p. 23
										25	S-A11N502A025T	p. 6	p. 23
										35	S-A11N502A035T	p. 6	p. 23
										45	S-A11N502A045T	p. 6	p. 23
										15	S-A11N502A015TRM	p. 6	p. 24
										25	S-A11N502A025TRM	p. 6	p. 24
										35	S-A11N502A035TRM	p. 6	p. 24
			45	S-A11N502A045TRM	p. 6	p. 24							
			5	S-A11N502A005N	p. 6	p. 12							
			10	S-A11N502A010N	p. 6	p. 13							
			30	S-A11N502A030N	p. 6	p. 20							
			60	S-A11N502A060N	p. 6	p. 20							
			180	S-A11N502A180N	p. 6	p. 20							
			15	S-A11N502A015N	p. 6	p. 23							
			25	S-A11N502A025N	p. 6	p. 23							
			35	S-A11N502A035N	p. 6	p. 23							
			45	S-A11N502A045N	p. 6	p. 23							
			15	S-A11N502A015NRM	p. 6	p. 24							
			25	S-A11N502A025NRM	p. 6	p. 24							
	35	S-A11N502A035NRM	p. 6	p. 24									
	45	S-A11N502A045NRM	p. 6	p. 24									
	5	S-A11N502A005S2	p. 6	p. 14									
	10	S-A11N502A010S2	p. 6	p. 15									
	30	S-A11N502A030S2	p. 6	p. 20									
	60	S-A11N502A060S2	p. 6	p. 20									
	180	S-A11N502A180S2	p. 6	p. 20									
	5	S-A11N502A005S2RM	p. 6	p. 14									
	10	S-A11N502A010S2RM	p. 6	p. 15									
	15	S-A11N502A015S2RM	p. 6	p. 24									
	25	S-A11N502A025S2RM	p. 6	p. 24									
	35	S-A11N502A035S2RM	p. 6	p. 24									
	45	S-A11N502A045S2RM	p. 6	p. 24									
	5	S-A11N103A005T	p. 8	p. 12									
	30	S-A11N103A030T	p. 8	p. 21									
	60	S-A11N103A060T	p. 8	p. 21									
	180	S-A11N103A180T	p. 8	p. 21									
	15	S-A11N103A015T	p. 8	p. 23									
	25	S-A11N103A025T	p. 8	p. 23									
	35	S-A11N103A035T	p. 8	p. 23									
	15	S-A11N103A015TRM	p. 8	p. 24									
	25	S-A11N103A025TRM	p. 8	p. 24									
	35	S-A11N103A035TRM	p. 8	p. 24									
	5	S-A11N103A005S2	p. 8	p. 14									
	10	S-A11N103A010S2	p. 8	p. 15									
	30	S-A11N103A030S2	p. 8	p. 21									
	60	S-A11N103A060S2	p. 8	p. 21									
	180	S-A11N103A180S2	p. 8	p. 21									
	5	S-A11N103A005S2RM	p. 8	p. 14									
	10	S-A11N103A010S2RM	p. 8	p. 15									
	15	S-A11N103A015S2RM	p. 8	p. 24									
	25	S-A11N103A025S2RM	p. 8	p. 24									
	35	S-A11N103A035S2RM	p. 8	p. 24									

(1) Up to four 5 kVA UPS units can be combined. The expansion can be done even after installation.

(2) At a 25°C ambient temperature and load power factor of 0.9 for a 5-minute backup model and 0.8 for a 10-minute backup model, using new, fully charged batteries.

(3) These are a set of a UPS unit(s) + battery(ies) + power distribution unit. The PDU is not included with some models.

Lineup Input and output connector types are indicated by the following icons: **T** Terminal block, **P** Plug, **C** Outlet

[No. of phases/wires] Input voltage	[No. of phases/wires] Output voltage	Output capacity		Scalability (Max. 20 kVA) ⁽¹⁾	Input connector	Output connector	Safety Standards	Free- standing	Rack mount	Battery backup time ⁽²⁾ (min)	Order no. ⁽³⁾	Page							
		[kVA]	[kW]									Specifications	Dimensions						
[Single-phase 2-wire] 200 v 200/208/220/ 230/240 V	[Single-phase 2-wire] 200 v 200/208/220/ 230/240 V	15	13.5	✓	T	T C	-	✓	-	5	S-A11N153A005S2	p. 10	p. 14						
										10	S-A11N153A010S2	p. 10	p. 15						
										30	S-A11N153A030S2	p. 10	p. 22						
										60	S-A11N153A060S2	p. 10	p. 22						
										180	S-A11N153A180S2	p. 10	p. 22						
		20	18	-	T	T C	-	✓	-	5	S-A11N153A005S2RM	p. 10	p. 14						
										10	S-A11N153A010S2RM	p. 10	p. 15						
										15	S-A11N153A015S2RM	p. 10	p. 25						
										5	S-A11N203A005S2	p. 11	p. 14						
										10	S-A11N203A010S2	p. 11	p. 15						
										30	S-A11N203A030S2	p. 11	p. 22						
										60	S-A11N203A060S2	p. 11	p. 22						
										180	S-A11N203A180S2	p. 11	p. 22						
										5	S-A11N203A005S2RM	p. 11	p. 14						
										10	S-A11N203A010S2RM	p. 11	p. 15						
15	S-A11N203A015S2RM	p. 11	p. 25																
[Single-phase 2-wire] 100 v or [Single-phase 2-wire] 200 v	[Single-phase 2-wire] 100 v or [Single-phase 3-wire] 100/200 v	5	4.5	-	T	T	-	✓	-	5	S-A11N502A005W1	p. 7	p. 16						
										10	S-A11N502A010W1	p. 7	p. 16						
										30	S-A11N502A030W1	p. 7	p. 20						
										60	S-A11N502A060W1	p. 7	p. 20						
										180	S-A11N502A180W1	p. 7	p. 20						
		10	9	-	T	T	-	✓	-	5	S-A11N103A005W1	p. 9	p. 16						
										10	S-A11N103A010W1	p. 9	p. 16						
										30	S-A11N103A030W1	p. 9	p. 21						
										60	S-A11N103A060W1	p. 9	p. 21						
		200 v	100/200 v	-	T	T	-	✓	-	180	S-A11N103A180W1	p. 9	p. 21						
										5	S-A11N502A005W2	p. 7	p. 17						
										10	S-A11N502A010W2	p. 7	p. 17						
										30	S-A11N502A030W2	p. 7	p. 20						
										60	S-A11N502A060W2	p. 7	p. 20						
										180	S-A11N502A180W2	p. 7	p. 20						
5	4.5									-	T	T	-	✓	-	5	S-A11N103A005W2	p. 9	p. 17
																10	S-A11N103A010W2	p. 9	p. 17
																30	S-A11N103A030W2	p. 9	p. 21
																60	S-A11N103A060W2	p. 9	p. 21
10	9	-	T	T	-	✓	-	180	S-A11N103A180W2	p. 9	p. 21								
								5	S-A11N502A005Z	p. 7	p. 18								
								10	S-A11N502A010Z	p. 7	p. 19								
								30	S-A11N502A030Z	p. 7	p. 20								
								60	S-A11N502A060Z	p. 7	p. 20								
								180	S-A11N502A180Z	p. 7	p. 20								
								5	4.5	✓	T	T	-	✓	-	5	S-A11N103A005Z	p. 9	p. 18
																10	S-A11N103A010Z	p. 9	p. 19
																30	S-A11N103A030Z	p. 9	p. 21
																60	S-A11N103A060Z	p. 9	p. 21
10	9	✓	T	T	-	✓	-	180	S-A11N103A180Z	p. 9	p. 21								
								5	S-A11N153A005Z	p. 10	p. 18								
								10	S-A11N153A010Z	p. 10	p. 19								
								30	S-A11N153A030Z	p. 10	p. 22								
								60	S-A11N153A060Z	p. 10	p. 22								
								180	S-A11N153A180Z	p. 10	p. 22								
								15	13.5	✓	T	T	-	✓	-	5	S-A11N203A005Z	p. 11	p. 18
																10	S-A11N203A010Z	p. 11	p. 19
																30	S-A11N203A030Z	p. 11	p. 22
																60	S-A11N203A060Z	p. 11	p. 22
20	18	-	T	T	-	✓	-	180	S-A11N203A180Z	p. 11	p. 22								
								5	S-A11N203A005Z	p. 11	p. 18								
								10	S-A11N203A010Z	p. 11	p. 19								
								30	S-A11N203A030Z	p. 11	p. 22								
[Single-phase 2-wire] 200 v 200/208/220/ 230/240 V	[Single-phase 2-wire] 200 v 200/208/220/ 230/240 V	5	4.5	-	T	T	✓	✓	✓	5	A11N502U0TM	p. 28	p. 29						
		10	9	-	T	T	✓	✓	✓	5	A11N103U0TM	p. 28	p. 29						

(1) Up to four 5 kVA UPS units can be combined. The expansion can be done even after installation.

(2) At a 25°C ambient temperature and load power factor of 0.9 for a 5-minute backup model and 0.8 for a 10-minute backup model, using new, fully charged batteries.

(3) These are a set of a UPS unit(s) + battery(ies) + power distribution unit. The PDU is not included with some models.

Specifications

Output capacity **5 kVA**

Order no.	5-minute backup model (3U) 10-minute backup model (4U)	S-A11N502A005T S-A11N502A010T	S-A11N502A005N S-A11N502A010N	S-A11N502A005S2△△△ ⁽¹⁾ S-A11N502A010S2△△△ ⁽¹⁾	
Rated output capacity (apparent power / active power)	Single-unit/Parallel operation (N config.) Parallel redundant operation (N+1 config.)	5 kVA / 4.5 kW —			
Technology	Topology	Double conversion online			
	Cooling system	Forced air cooling			
	Inverter	High-frequency PWM			
AC input	No. of phases/wires	Single-phase 2-wire			
	Rated voltage	200/208/220/230/240 V (Same as output voltage)			
	Voltage range ⁽²⁾	Within -40 to +15% of rated voltage			
	Rated frequency	50/60 Hz (Auto-sensing or fixed-frequency mode selectable. ⁽³⁾ Factory setting: auto-sensing)			
	Required capacity	N config.	5.5 kVA or less		
		N+1 config.	—		
Input power factor	0.95 or greater (at rated input voltage, input voltage harmonic distortion < 1%)				
AC output	No. of phases/wires	Single-phase 2-wire			
	Rated voltage	200/208/220/230/240 V (Selectable. Factory setting: 200 V)			
	Voltage regulation	Within ±2% of rated voltage			
	Rated frequency	50/60 Hz (Same as input frequency)			
	Frequency regulation ⁽²⁾	In grid operation	Within ±1/3/5% of rated frequency (Selectable. Factory setting: ±3%)		
		At free run (asynchronous)	Within ±0.5% of rated frequency		
	Voltage waveform	Sinusoidal			
	Voltage harmonic distortion	At linear load	3% or less (At rated output)		
		At rectifier load	7% or less (At rated output)		
	Load power factor	Rated	0.9 lagging (Variation range: 0.7 lagging to 1.0)		
	Transient voltage fluctuation	For abrupt load change	Within ±5% of rated voltage (For 10⇔100% abrupt change)		
		For loss/return of input power	Within ±5% of rated voltage		
		For abrupt input voltage change	Within ±5% of rated voltage (For ±10% abrupt change)		
	Overcurrent protection	N config.	110% or more (Automatic transfer to bypass circuit ⁽⁴⁾ if exceeded)		
		N+1 config.	—		
	Overload capability	Inverter	N config.	110% (for 1 min), 118% (instantly)	
N+1 config.			—		
Bypass		N config.	200% (for 30 s), 800% (for 2 cycles)		
N+1 config.	—				
Battery	Type	Small-sized valve-regulated lead-acid (VRLA) battery			
	Backup time	5 min (At 25°C ambient temperature and load power factor of 0.9, using new, fully charged batteries) or 10 min (At 25°C ambient temperature and load power factor of 0.8, using new, fully charged batteries)			
	Quantity	16 pcs (12 V per battery)			
	Total capacity	5-minute backup models: 1200 Wh, 10-minute backup models: 1632 Wh			
	Expected life	5 years (At a 25°C ambient temperature. For reference purposes only.)			
Acoustic noise (1 m from front of UPS, A-weighted)	Excluding start of charging	45 dB or less			
	At start of charging	51 dB or less			
Heat dissipation (at rated output after fully charged)	287 W				
Input leakage current	5 mA or less			22 mA or less	
I/O connector, wire gauge, etc. ⁽⁵⁾	Input connector	M6 terminal	NEMA L6-30P	M8 terminal	
		Input wire	8 mm ²	—	8 mm ²
	Output connector	M6 terminal NEMA L6-30R ×1 IEC-C13 ×2	NEMA L6-30R ×2 NEMA L6-20R ×2	M8 terminal NEMA L6-30R ×4	
		Output wire	8 mm ²	—	8 mm ²
	Grounding wire	5.5 mm ²	—	8 mm ²	
	Input distribution board breaker capacity	40 A or more	30 A or more	40 A or more	
Operating environment	Temperature: 0 to 40°C, humidity: 10 to 90% RH (non-condensing)				
Storage environment ⁽⁶⁾	Temperature: -15 to +50°C, humidity: 10 to 90% RH (non-condensing)				
Expected service life (of the UPS unit excluding battery)	10 years (At a 30°C average ambient temperature. For reference purposes only.)				
EMC standard	Compliant with VCCI 32-1 Class A ⁽⁷⁾			—	
UPS classification according to IEC standard	VFI-SS-111				
Separate options					
Rack support rails ⁽⁸⁾	5-minute backup	RM027-US (3U, 1 pair)		RM027-US (3U, 1 pair), RM028-US (4U, 1 pair)	
	10-minute backup	RM028-US (4U, 1 pair)		RM028-US (4U, 2 pairs)	
Floor mounting brackets ⁽⁹⁾	—			FMA11NA00 (1 pc)	
Air filter kit ⁽¹⁰⁾	FLA11NA00-3U (3U, 1 pc) or FLA11NA00-4U (4U, 1 pc)				
Replacement battery pack model no.	BPA11N006A00M (3U, 2 pcs) or BPA11N009A00M (4U, 2 pcs)				

- (1) The rack mount models have model numbers ending in "RM" in place of wildcard characters.
 - (2) AC input voltage range changes depending on the load level. The input voltage range is within -40% to +15% of the rated value at load levels ≤ 70%, and is within -20% to +15% of the rated value at load levels > 70%. For S-A11N502A005N (NEMA plug type), the input voltage range is within -40% to +15% of the rated value at load levels ≤ 70%, and is within -10% to +15% of the rated value at load levels > 70%.
 - (3) At the auto-sensing setting, the frequency synchronizing range can be set to ±1, 3, or 5%. At the auto-sensing setting, the input frequency range is within ±8% of the rated frequency. Also, for the inverter to start running, the input frequency must be within the set synchronizing frequency range. When fixed-frequency setting is selected, output frequency is fixed to either 50 Hz or 60 Hz regardless of input frequency. At the fixed-frequency setting, the input frequency range is 40 to 120 Hz.
 - (4) Uninterrupted transfer to the bypass circuit is only possible when all of the following conditions are true: the frequency setting is set to automatic; input frequency is within the synchronizing range; input voltage is within the allowable range.
 - (5) Communications:
 - a. Dry contact signal: D-sub 15-pin female, with M3 fixing screws
 - b. PC port: USB Type C
 - c. Remote control: One-touch terminal block, compatible wire size: 24 to 16 AWG
 - (6) Avoid use or storage in 30°C or higher temperatures for extended periods of time, or the battery life will shorten. If a UPS is to be stored for a long period, it will be necessary to recharge batteries once every two to six months.
 - (7) 5-minute backup models (3U) only
 - (8) Used for mounting the UPS on an EIA standard 19-inch rack. Prior to purchase, check that the rails are mountable to your 19-inch rack.
 - (9) Used to secure the UPS to the floor.
 - (10) Front side air intake filter to prevent dust ingress.
- Note 1: Output power is supplied from the inverter at start-up. (Inverter start-up type)
 Note 2: The Instruction Manuals included with these models are in Japanese.

Specifications

Output capacity **5 kVA**

Order no.		5-minute backup model (3U)	S-A11N502A005W1	S-A11N502A005W2	S-A11N502A005Z	
		10-minute backup model (4U)	S-A11N502A010W1	S-A11N502A010W2	S-A11N502A010Z	
Rated output capacity (apparent power / active power)		Single-unit/Parallel operation (N config.)	5 kVA / 4.5 kW			
		Parallel redundant operation (N+1 config.)	—			
Technology		Topology	Double conversion online			
		Cooling system	Forced air cooling			
		Inverter	High-frequency PWM			
AC input	No. of phases/wires	Single-phase 2-wire				
	Rated voltage	100/200 V		200 V		
	Voltage range ⁽¹⁾	Within -35 to +15% of rated voltage		Within -40 to +15% of rated voltage		
	Rated frequency	50/60 Hz (Auto-sensing or fixed-frequency mode selectable. ⁽²⁾ Factory setting: auto-sensing)				
	Required capacity	N config.	6 kVA or less			
		N+1 config.	—			
Input power factor	0.95 or greater (at rated input voltage, input voltage harmonic distortion < 1%)					
AC output	No. of phases/wires	Single-phase 2-wire or single-phase 3-wire				
	Rated voltage	100 V (2-wire) or 100/200 V (3-wire)				
	Voltage regulation	Within ±5% of rated voltage				
	Rated frequency	50/60 Hz (Same as input frequency)				
	Frequency regulation ⁽²⁾	In grid operation	Within ±1/3/5% of rated frequency (Selectable. Factory setting: ±3%)			
		At free run (asynchronous)	Within ±0.5% of rated frequency			
	Voltage waveform	Sinusoidal				
	Voltage harmonic distortion	At linear load	3% or less (At rated output)			
		At rectifier load	—			
	Load power factor	Rated	0.9 lagging (Variation range: 0.7 lagging to 1.0)			
		Transient voltage fluctuation	For abrupt load change	Within ±5% of rated voltage (For 20↔100% abrupt change)		
			For loss/return of input power	Within ±5% of rated voltage		
		For abrupt input voltage change	Within ±5% of rated voltage (For ±10% abrupt change)			
	Overcurrent protection	N config.	104% or more (Automatic transfer to bypass circuit ⁽³⁾ if exceeded)			
		N+1 config.	—			
	Overload capability	Inverter	N config.	104% (for 1 min), 112% (instantly)		
			N+1 config.	—		
Bypass		N config.	200% (for 30 s), 800% (for 2 cycles)			
		N+1 config.	—			
Battery	Type	Small-sized valve-regulated lead-acid (VRLA) battery				
	Backup time	5 min (At 25°C ambient temperature and load power factor of 0.9, using new, fully charged batteries) or 10 min (At 25°C ambient temperature and load power factor of 0.8, using new, fully charged batteries)				
	Quantity	16 pcs (12 V per battery)				
	Total capacity	5-minute backup models: 1200 Wh, 10-minute backup models: 1632 Wh				
	Expected life	5 years (At a 25°C ambient temperature. For reference purposes only.)				
Acoustic noise (1 m from front of UPS, A-weighted)	Excluding start of charging	50 dB or less				
	At start of charging	55 dB or less				
Heat dissipation (at rated output after fully charged)	673 W		500 W			
Input leakage current	20 mA or less					
I/O connector, wire gauge, etc. ⁽⁴⁾	Input connector		M8 terminal			
	Input wire	100 V	22 mm ²		—	
		200 V	8 mm ²		—	
	Output connector		M8 terminal			
	Output wire		14 mm ² (2-wire), 8 mm ² (3-wire)			
	Grounding wire		8 mm ²			
	Input distribution board breaker capacity	100 V	80 A or more		—	
		200 V	40 A or more		60 A or more	
				40 A or more		
Operating environment	Temperature: 0 to 40°C, humidity: 10 to 90% RH (non-condensing)					
Storage environment ⁽⁵⁾	Temperature: -15 to +50°C, humidity: 10 to 90% RH (non-condensing)					
Expected service life (of the UPS unit excluding battery)	10 years (At a 30°C average ambient temperature. For reference purposes only.)					
EMC standard	—					
UPS classification according to IEC standard	VFI-XX-111					
Separate options						
Floor mounting brackets ⁽⁶⁾	FMA11NA00 (1 pc)					
Air filter kit ⁽⁷⁾	FLA11NA00-3U (3U, 1 pc) or FLA11NA00-4U (4U, 1 pc)					
Replacement battery pack model no.	BPA11N006A00M (3U, 2 pcs) or BPA11N009A00M (4U, 2 pcs)					

- (1) AC input voltage range changes depending on the load level.
For model numbers ending in "W1": the input voltage range is within -35% to +15% of the rated value at load levels ≤ 70%, and is within ±15% of the rated value at load levels > 70% (The lower limit is -15% when returning from outside the range.)
For model numbers ending in "W2" or "Z": the input voltage range is within -40% to +15% of the rated value at load levels ≤ 70%, and is within -20% to +15% of the rated value at load levels > 70% (The lower limit is -20% when returning from outside the range.)
- (2) At the auto-sensing setting, the frequency synchronizing range can be set to ±1, 3, or 5%. At the auto-sensing setting, the input frequency range is within ±8% of the rated frequency. Also, for the inverter to start running, the input frequency must be within the set synchronizing frequency range. When fixed-frequency setting is selected, output frequency is fixed to either 50 Hz or 60 Hz regardless of input frequency. At the fixed-frequency setting, the input frequency range is 40 to 120 Hz.
- (3) Uninterrupted transfer to the bypass circuit is only possible when all of the following conditions are true: the frequency setting is set to automatic; input frequency is within the synchronizing range; input voltage is within the allowable range.
- (4) Communications:
a. Dry contact signal: D-sub 15-pin female, with M3 fixing screws
b. PC port: USB Type C
c. Remote control: One-touch terminal block, compatible wire size: 24 to 16 AWG
- (5) Avoid use or storage in 30°C or higher temperatures for extended periods of time, or the battery life will shorten. If a UPS is to be stored for a long period, it will be necessary to recharge batteries once every two to six months.
- (6) Used to secure the UPS to the floor.
- (7) Front side air intake filter to prevent dust ingress.
- Note 1: Output power is supplied from the inverter at start-up. (Inverter start-up type)
Note 2: The Instruction Manuals included with these models are in Japanese.

Specifications

Output capacity **10 kVA**

Order no.	5-minute backup model (3U) 10-minute backup model (4U)	S-A11N103A005T —	S-A11N103A005S2 △△△ ⁽¹⁾ S-A11N103A010S2 △△△ ⁽¹⁾
Rated output capacity (apparent power / active power)	Single-unit/Parallel operation (N config.) Parallel redundant operation (N+1 config.)	10 kVA / 9 kW 5 kVA / 4.5 kW	
Technology	Topology Cooling system Inverter	Double conversion online Forced air cooling High-frequency PWM	
AC input	No. of phases/wires	Single-phase 2-wire	
	Rated voltage	200/208/220/230/240 V (Same as output voltage)	
	Voltage range ⁽²⁾	Within -40 to +15% of rated voltage	
	Rated frequency	50/60 Hz (Auto-sensing or fixed-frequency mode selectable. ⁽³⁾ Factory setting: auto-sensing)	
	Required capacity	N config. N+1 config.	11 kVA or less 6.2 kVA or less
AC output	No. of phases/wires	Single-phase 2-wire	
	Rated voltage	200/208/220/230/240 V (Selectable. Factory setting: 200 V)	
	Voltage regulation	Within ±2% of rated voltage	
	Rated frequency	50/60 Hz (Same as input frequency)	
	Frequency regulation ⁽⁵⁾	In grid operation At free run (asynchronous)	Within ±1/3/5% of rated frequency (Selectable. Factory setting: ±3%) Within ±0.5% of rated frequency
	Voltage waveform	Sinusoidal	
	Voltage harmonic distortion	At linear load At rectifier load	3% or less (At rated output) 7% or less (At rated output)
	Load power factor	Rated	0.9 lagging (Variation range: 0.7 lagging to 1.0)
	Transient voltage fluctuation	For abrupt load change	Within ±5% of rated voltage (For 10⇒100% abrupt change)
		For loss/return of input power	Within ±5% of rated voltage
		For abrupt input voltage change	Within ±5% of rated voltage (For ±10% abrupt change)
	Overcurrent protection	N config. N+1 config.	110% or more (Automatic transfer to bypass circuit ⁽⁴⁾ if exceeded) 220% or more (Automatic transfer to bypass circuit ⁽⁴⁾ if exceeded)
		Overload capability	Inverter N config. N+1 config.
	Bypass N config. N+1 config.		200% (for 30 s), 800% (for 2 cycles) 400% (for 30 s), 1600% (for 2 cycles)
Battery	Type	Small-sized valve-regulated lead-acid (VRLA) battery	
	Backup time	5 min (At 25°C ambient temperature and load power factor of 0.9, using new, fully charged batteries) or 10 min (At 25°C ambient temperature and load power factor of 0.8, using new, fully charged batteries)	
	Quantity	32 pcs (12 V per battery)	
	Total capacity	5-minute backup models: 2400 Wh, 10-minute backup models: 3264 Wh	
	Expected life	5 years (At a 25°C ambient temperature. For reference purposes only.)	
Acoustic noise (1 m from front of UPS, A-weighted)	Excluding start of charging	50 dB or less	
	At start of charging	53 dB or less	
Heat dissipation (at rated output after fully charged)	574 W		
Input leakage current	18 mA or less		28 mA or less
I/O connector, wire gauge, etc. ⁽⁵⁾	Input connector	M6 terminal	
	Input wire	22 mm ²	
	Output connector	M6 terminal NEMA L6-30R ×2 NEMA L6-20R ×2	M8 terminal NEMA L6-30R ×4
	Output wire	22 mm ²	
	Grounding wire	14 mm ²	
	Input distribution board breaker capacity	80 A or more	
Operating environment	Temperature: 0 to 40°C, humidity: 10 to 90% RH (non-condensing)		
Storage environment ⁽⁶⁾	Temperature: -15 to +50°C, humidity: 10 to 90% RH (non-condensing)		
Expected service life (of the UPS unit excluding battery)	10 years (At a 30°C average ambient temperature. For reference purposes only.)		
EMC standard	Compliant with VCCI 32-1 Class A ⁽⁷⁾		—
UPS classification according to IEC standard	VFI-SS-111		
Separate options			
Rack support rails ⁽⁸⁾	5-minute backup	RM027-US (3U, 2 pairs)	
	10-minute backup	— RM028-US (4U, 3 pairs)	
Floor mounting brackets ⁽⁹⁾	— FMA11NA00 (1 pc)		
Air filter kit ⁽¹⁰⁾	FLA11NA00-3U (3U, 2 pcs) or FLA11NA00-4U (4U, 2 pcs)		
Replacement battery pack model no.	BPA11N006A00M (3U, 4 pcs) or BPA11N009A00M (4U, 4 pcs)		

- (1) The rack mount models have model numbers ending in "RM" in place of wildcard characters.
- (2) AC input voltage range changes depending on the load level. The input voltage range is within -40% to +15% of the rated value at load levels ≤ 70%, and is within -20% to +15% of the rated value at load levels > 70%.
- (3) At the auto-sensing setting, the frequency synchronizing range can be set to ±1, 3, or 5%. At the auto-sensing setting, the input frequency range is within ±8% of the rated frequency. Also, for the inverter to start running, the input frequency must be within the set synchronizing frequency range. When fixed-frequency setting is selected, output frequency is fixed to either 50 Hz or 60 Hz regardless of input frequency. At the fixed-frequency setting, the input frequency range is 40 to 120 Hz.
- (4) Uninterrupted transfer to the bypass circuit is only possible when all of the following conditions are true: the frequency setting is set to automatic; input frequency is within the synchronizing range; input voltage is within the allowable range.
- (5) Communications:
a. Dry contact signal: D-sub 15-pin female, with M3 fixing screws
b. PC port: USB Type C
c. Remote control: One-touch terminal block, compatible wire size: 24 to 16 AWG
- (6) Avoid use or storage in 30°C or higher temperatures for extended periods of time, or the battery life will shorten. If a UPS is to be stored for a long period, it will be necessary to recharge batteries once every two to six months.
- (7) 5-minute backup models (3U) only
- (8) Used for mounting the UPS on an EIA standard 19-inch rack. Prior to purchase, check that the rails are mountable to your 19-inch rack.
- (9) Used to secure the UPS to the floor.
- (10) Front side air intake filter to prevent dust ingress.
Note 1: Output power is supplied from the inverter at start-up. (Inverter start-up type)
Note 2: The Instruction Manuals included with these models are in Japanese.

Specifications

Output capacity **10 kVA**

Order no.		5-minute backup model (3U)	S-A11N103A005W1	S-A11N103A005W2	S-A11N103A005Z	
		10-minute backup model (4U)	S-A11N103A010W1	S-A11N103A010W2	S-A11N103A010Z	
Rated output capacity (apparent power / active power)		Single-unit/Parallel operation (N config.)	10 kVA / 9 kW			
		Parallel redundant operation (N+1 config.)	5 kVA / 4.5 kW			
Technology		Topology	Double conversion online			
		Cooling system	Forced air cooling			
		Inverter	High-frequency PWM			
AC input	No. of phases/wires		Single-phase 2-wire			
	Rated voltage		100/200 V	200 V		
	Voltage range ⁽¹⁾		Within -35 to +15% of rated voltage		Within -40 to +15% of rated voltage	
	Rated frequency		50/60 Hz (Auto-sensing or fixed-frequency mode selectable. ⁽²⁾ Factory setting: auto-sensing)			
	Required capacity		N config.	12 kVA or less		
			N+1 config.	6.7 kVA or less		
		Input power factor	0.95 or greater (at rated input voltage, input voltage harmonic distortion < 1%)			
AC output	No. of phases/wires		Single-phase 2-wire or single-phase 3-wire			
	Rated voltage		100 V (2-wire) or 100/200 V (3-wire)			
	Voltage regulation		Within $\pm 5\%$ of rated voltage			
	Rated frequency		50/60 Hz (Same as input frequency)			
	Frequency regulation ⁽²⁾		In grid operation	Within $\pm 1/3/5\%$ of rated frequency (Selectable. Factory setting: $\pm 3\%$)		
			At free run (asynchronous)	Within $\pm 0.5\%$ of rated frequency		
	Voltage waveform		Sinusoidal			
	Voltage harmonic distortion		At linear load	3% or less (At rated output)		
			At rectifier load	—		
	Load power factor		Rated	0.9 lagging (Variation range: 0.7 lagging to 1.0)		
	Transient voltage fluctuation		For abrupt load change	Within $\pm 5\%$ of rated voltage (For 20 \leftrightarrow 100% abrupt change)		
			For loss/return of input power	Within $\pm 5\%$ of rated voltage		
			For abrupt input voltage change	Within $\pm 5\%$ of rated voltage (For $\pm 10\%$ abrupt change)		
	Overcurrent protection		N config.	104% or more (Automatic transfer to bypass circuit ⁽³⁾ if exceeded)		
			N+1 config.	208% or more (Automatic transfer to bypass circuit ⁽³⁾ if exceeded)		
Overload capability		Inverter	N config.	104% (for 1 min), 112% (instantly)		
			N+1 config.	208% (for 1 min), 224% (instantly)		
		Bypass	N config.	200% (for 30 s), 800% (for 2 cycles)		
			N+1 config.	400% (for 30 s), 1600% (for 2 cycles)		
Battery	Type		Small-sized valve-regulated lead-acid (VRLA) battery			
	Backup time		5 min (At 25°C ambient temperature and load power factor of 0.9, using new, fully charged batteries) or 10 min (At 25°C ambient temperature and load power factor of 0.8, using new, fully charged batteries)			
	Quantity		32 pcs (12 V per battery)			
	Total capacity		5-minute backup models: 2400 Wh, 10-minute backup models: 3264 Wh			
	Expected life		5 years (At a 25°C ambient temperature. For reference purposes only.)			
Acoustic noise (1 m from front of UPS, A-weighted)		Excluding start of charging	55 dB or less			
		At start of charging	55 dB or less			
Heat dissipation (at rated output after fully charged)			1345 W	1000 W		
Input leakage current			25 mA or less			
I/O connector, wire gauge, etc. ⁽⁴⁾	Input connector		M8 terminal			
	Input wire		100 V	38 mm ²		
			200 V	22 mm ²		
	Output connector		M8 terminal			
	Output wire		38 mm ² (2-wire), 14 mm ² (3-wire)			
	Grounding wire		14 mm ²			
	Input distribution board breaker capacity		100 V	160 A or more		
		200 V	80 A or more	125 A or more		
Operating environment		Temperature: 0 to 40°C, humidity: 10 to 90% RH (non-condensing)				
Storage environment ⁽⁵⁾		Temperature: -15 to +50°C, humidity: 10 to 90% RH (non-condensing)				
Expected service life (of the UPS unit excluding battery)		10 years (At a 30°C average ambient temperature. For reference purposes only.)				
EMC standard		—				
UPS classification according to IEC standard		VFI-XX-11				
Separate options						
Floor mounting brackets ⁽⁶⁾		FMA11NA00 (1 pc)				
Air filter kit ⁽⁷⁾		FLA11NA00-3U (3U, 2 pcs) or FLA11NA00-4U (4U, 2 pcs)				
Replacement battery pack model no.		BPA11N006A00M (3U, 4 pcs) or BPA11N009A00M (4U, 4 pcs)				

(1) AC input voltage range changes depending on the load level.

For model numbers ending in "W1": the input voltage range is within -35% to +15% of the rated value at load levels $\leq 70\%$, and is within $\pm 15\%$ of the rated value at load levels $> 70\%$ (The lower limit is -15% when returning from outside the range).

For model numbers ending in "W2" or "Z": the input voltage range is within -40% to +15% of the rated value at load levels $\leq 70\%$, and is within -20% to +15% of the rated value at load levels $> 70\%$ (The lower limit is -20% when returning from outside the range).

(2) At the auto-sensing setting, the frequency synchronizing range can be set to $\pm 1, 3$, or 5%. At the auto-sensing setting, the input frequency range is within $\pm 8\%$ of the rated frequency. Also, for the inverter to start running, the input frequency must be within the set synchronizing frequency range. When fixed-frequency setting is selected, output frequency is fixed to either 50 Hz or 60 Hz regardless of input frequency. At the fixed-frequency setting, the input frequency range is 40 to 120 Hz.

(3) Uninterrupted transfer to the bypass circuit is only possible when all of the following conditions are true: the frequency setting is set to automatic; input frequency is within the synchronizing range; input voltage is within the allowable range.

(4) Communications:

- Dry contact signal: D-sub 15-pin female, with M3 fixing screws
- PC port: USB Type C

c. Remote control: One-touch terminal block, compatible wire size: 24 to 16 AWG

(5) Avoid use or storage in 30°C or higher temperatures for extended periods of time, or the battery life will shorten. If a UPS is to be stored for a long period, it will be necessary to recharge batteries once every two to six months.

(6) Used to secure the UPS to the floor.

(7) Front side air intake filter to prevent dust ingress.

Note 1: Output power is supplied from the inverter at start-up. (Inverter start-up type)

Note 2: The Instruction Manuals included with these models are in Japanese.

Specifications

Output capacity **15 kVA**

Order no.	5-minute backup model (3U) 10-minute backup model (4U)	S-A11N153A005S2△△ ⁽¹⁾ S-A11N153A010S2△△ ⁽¹⁾	S-A11N153A005Z S-A11N153A010Z	
Rated output capacity (apparent power / active power)	Single-unit/Parallel operation (N config.) Parallel redundant operation (N+1 config.)	15 kVA / 13.5 kW 10 kVA / 9 kW		
Technology	Topology	Double conversion online		
	Cooling system	Forced air cooling		
	Inverter	High-frequency PWM		
AC input	No. of phases/wires	Single-phase 2-wire		
	Rated voltage	200/208/220/230/240 V (Same as output voltage)	200 V	
	Voltage range ⁽²⁾	Within -40 to +15% of rated voltage		
	Rated frequency	50/60 Hz (Auto-sensing or fixed-frequency mode selectable. ⁽³⁾ Factory setting: auto-sensing)		
	Required capacity	N config.	16.5 kVA or less	18 kVA or less
		N+1 config.	11.7 kVA or less	12.7 kVA or less
Input power factor	0.95 or greater (at rated input voltage, input voltage harmonic distortion < 1%)			
AC output	No. of phases/wires	Single-phase 2-wire	Single-phase 2-wire or single-phase 3-wire	
	Rated voltage	200/208/220/230/240 V (Selectable. Factory setting: 200 V)	100 V (2-wire) or 100/200 V (3-wire)	
	Voltage regulation	Within ±2% of rated voltage		
	Rated frequency	50/60 Hz (Same as input frequency)		
	Frequency regulation ⁽⁵⁾	In grid operation	Within ±1/3/5% of rated frequency (Selectable. Factory setting: ±3%)	
		At free run (asynchronous)	Within ±0.5% of rated frequency	
	Voltage waveform	Sinusoidal		
	Voltage harmonic distortion	At linear load	3% or less (At rated output)	3% or less (At rated output)
		At rectifier load	7% or less (At rated output)	—
	Load power factor	Rated	0.9 lagging (Variation range: 0.7 lagging to 1.0)	
	Transient voltage fluctuation	For abrupt load change	Within ±5% of rated voltage (For 10⇔100% abrupt change)	Within ±5% of rated voltage (For 20⇔100% abrupt change)
		For loss/return of input power	Within ±5% of rated voltage	
		For abrupt input voltage change	Within ±5% of rated voltage (For ±10% abrupt change)	
	Overcurrent protection	N config.	110% or more (Automatic transfer to bypass circuit ⁽⁴⁾ if exceeded)	104% or more (Automatic transfer to bypass circuit ⁽⁴⁾ if exceeded)
		N+1 config.	165% or more (Automatic transfer to bypass circuit ⁽⁴⁾ if exceeded)	156% or more (Automatic transfer to bypass circuit ⁽⁴⁾ if exceeded)
Overload capability	Inverter	N config.	110% (for 1 min), 118% (instantly)	
		N+1 config.	165% (for 1 min), 177% (instantly)	
	Bypass	N config.	200% (for 30 s), 800% (for 2 cycles)	
		N+1 config.	300% (for 30 s), 1200% (for 2 cycles)	
Battery	Type	Small-sized valve-regulated lead-acid (VRLA) battery		
	Backup time	5 min (At 25°C ambient temperature and load power factor of 0.9, using new, fully charged batteries) or 10 min (At 25°C ambient temperature and load power factor of 0.8, using new, fully charged batteries)		
	Quantity	48 pcs (12 V per battery)		
	Total capacity	5-minute backup models: 3600 Wh, 10-minute backup models: 4896 Wh		
	Expected life	5 years (At a 25°C ambient temperature. For reference purposes only.)		
Acoustic noise (1 m from front of UPS, A-weighted)	Excluding start of charging	55 dB or less		
	At start of charging	55 dB or less		
Heat dissipation (at rated output after fully charged)		862 W	1500 W	
Input leakage current		34 mA or less	30 mA or less	
I/O connector, wire gauge, etc. ⁽⁵⁾	Input connector	M8 terminal		
	Input wire	38 mm ²		
	Output connector	M8 terminal NEMA L6-30R ×4	M8 terminal	
	Output wire	38 mm ²	22 mm ² ×2 (2-wire), 38 mm ² (3-wire)	
	Grounding wire	14 mm ²		
Input distribution board breaker capacity	125 A or more			
Operating environment	Temperature: 0 to 40°C, humidity: 10 to 90% RH (non-condensing)			
Storage environment ⁽⁶⁾	Temperature: -15 to +50°C, humidity: 10 to 90% RH (non-condensing)			
Expected service life (of the UPS unit excluding battery)	10 years (At a 30°C average ambient temperature. For reference purposes only.)			
EMC standard	—			
UPS classification according to IEC standard	VFI-SS-111	VFI-XX-111		
Separate options				
Rack support rails ⁽⁷⁾	5-minute backup	RM027-US (3U, 3 pairs), RM028-US (4U, 1 pair)	—	
	10-minute backup	RM028-US (4U, 4 pairs)	—	
Floor mounting brackets ⁽⁸⁾	FMA11NA00 (1 pc)			
Air filter kit ⁽⁹⁾	FLA11NA00-3U (3U, 3 pcs) or FLA11NA00-4U (4U, 3 pcs)			
Replacement battery pack model no.	BPA11N006A00M (3U, 6 pcs) or BPA11N009A00M (4U, 6 pcs)			

- (1) The rack mount models have model numbers ending in "RM" in place of wildcard characters.
- (2) AC input voltage range changes depending on the load level. The input voltage range is within -40% to +15% of the rated value at load levels ≤ 70%, and is within -20% to +15% of the rated value at load levels > 70%.
- (3) At the auto-sensing setting, the frequency synchronizing range can be set to ±1, 3, or 5%. At the auto-sensing setting, the input frequency range is within ±8% of the rated frequency. Also, for the inverter to start running, the input frequency must be within the set synchronizing frequency range. When fixed-frequency setting is selected, output frequency is fixed to either 50 Hz or 60 Hz regardless of input frequency. At the fixed-frequency setting, the input frequency range is 40 to 120 Hz.
- (4) Uninterrupted transfer to the bypass circuit is only possible when all of the following conditions are true: the frequency setting is set to automatic; input frequency is within the synchronizing range; input voltage is within the allowable range.
- (5) Communications:
 a. Dry contact signal: D-sub 15-pin female, with M3 fixing screws
 b. PC port: USB Type C
 c. Remote control: One-touch terminal block, compatible wire size: 24 to 16 AWG
- (6) Avoid use or storage in 30°C or higher temperatures for extended periods of time, or the battery life will shorten. If a UPS is to be stored for a long period, it will be necessary to recharge batteries once every two to six months.
- (7) Used for mounting the UPS on an EIA standard 19-inch rack. Prior to purchase, check that the rails are mountable to your 19-inch rack.
- (8) Used to secure the UPS to the floor.
- (9) Front side air intake filter to prevent dust ingress.
- Note 1: Output power is supplied from the inverter at start-up. (Inverter start-up type)
 Note 2: The Instruction Manuals included with these models are in Japanese.

Specifications

Output capacity 20 kVA

Order no.		5-minute backup model (3U)	S-A11N203A005S2△△△ ⁽¹⁾	S-A11N203A005Z	
		10-minute backup model (4U)	S-A11N203A010S2△△△ ⁽¹⁾	S-A11N203A010Z	
Rated output capacity (apparent power / active power)		Single-unit/Parallel operation (N config.)	20 kVA / 18 kW		
		Parallel redundant operation (N+1 config.)	15 kVA / 13.5 kW		
Technology		Topology	Double conversion online		
		Cooling system	Forced air cooling		
		Inverter	High-frequency PWM		
AC input	No. of phases/wires	Single-phase 2-wire			
	Rated voltage	200/208/220/230/240 V (Same as output voltage)		200 V	
	Voltage range ⁽²⁾	Within -40 to +15% of rated voltage			
	Rated frequency	50/60 Hz (Auto-sensing or fixed-frequency mode selectable.(3) Factory setting: auto-sensing)			
	Required capacity	N config.	22 kVA or less	24 kVA or less	
		N+1 config.	17.2 kVA or less	18.7 kVA or less	
Input power factor	0.95 or greater (at rated input voltage, input voltage harmonic distortion < 1%)				
AC output	No. of phases/wires	Single-phase 2-wire		Single-phase 2-wire or single-phase 3-wire	
	Rated voltage	200/208/220/230/240 V (Selectable. Factory setting: 200 V)		100 V (2-wire) or 100/200 V (3-wire)	
	Voltage regulation	Within ±2% of rated voltage		Within ±5% of rated voltage	
	Rated frequency	50/60 Hz (Same as input frequency)			
	Frequency regulation ⁽³⁾	In grid operation	Within ±1/3/5% of rated frequency (Selectable. Factory setting: ±3%)		
		At free run (asynchronous)	Within ±0.5% of rated frequency		
	Voltage waveform	Sinusoidal			
	Voltage harmonic distortion	At linear load	3% or less (At rated output)	3% or less (At rated output)	
		At rectifier load	7% or less (At rated output)	—	
	Load power factor	Rated	0.9 lagging (Variation range: 0.7 lagging to 1.0)		
	Transient voltage fluctuation	For abrupt load change	Within ±5% of rated voltage (For 10↔100% abrupt change)		Within ±5% of rated voltage (For 20↔100% abrupt change)
		For loss/return of input power	Within ±5% of rated voltage		
		For abrupt input voltage change	Within ±5% of rated voltage (For ±10% abrupt change)		
	Overcurrent protection	N config.	110% or more (Automatic transfer to bypass circuit ⁽⁴⁾ if exceeded)	104% or more (Automatic transfer to bypass circuit ⁽⁴⁾ if exceeded)	
		N+1 config.	147% or more (Automatic transfer to bypass circuit ⁽⁴⁾ if exceeded)	138% or more (Automatic transfer to bypass circuit ⁽⁴⁾ if exceeded)	
	Overload capability	Inverter	N config.	110% (for 1 min), 118% (instantly)	104% (for 1 min), 112% (instantly)
			N+1 config.	147% (for 1 min), 157% (instantly)	138% (for 1 min), 149% (instantly)
Bypass		N config.	200% (for 30 s), 800% (for 2 cycles)		
		N+1 config.	267% (for 30 s), 1067% (for 2 cycles)		
Battery	Type	Small-sized valve-regulated lead-acid (VRLA) battery			
	Backup time	5 min (At 25°C ambient temperature and load power factor of 0.9, using new, fully charged batteries) or 10 min (At 25°C ambient temperature and load power factor of 0.8, using new, fully charged batteries)			
	Quantity	64 pcs (12 V per battery)			
	Total capacity	5-minute backup models: 4800 Wh, 10-minute backup models: 6528 Wh			
	Expected life	5 years (At a 25°C ambient temperature. For reference purposes only.)			
Acoustic noise (1 m from front of UPS, A-weighted)	Excluding start of charging	55 dB or less			
	At start of charging	55 dB or less			
Heat dissipation (at rated output after fully charged)	1149 W		2000 W		
Input leakage current	40 mA or less		35 mA or less		
I/O connector, wire gauge, etc. ⁽⁵⁾	Input connector	M8 terminal			
	Input wire	60 mm ²			
	Output connector	M8 terminal NEMA L6-30R ×4	M8 terminal		
	Output wire	60 mm ²	38 mm ² ×2 (2-wire), 60 mm ² (3-wire)		
	Grounding wire	14 mm ²			
Input distribution board breaker capacity	160 A or more				
Operating environment	Temperature: 0 to 40°C, humidity: 10 to 90% RH (non-condensing)				
Storage environment ⁽⁶⁾	Temperature: -15 to +50°C, humidity: 10 to 90% RH (non-condensing)				
Expected service life (of the UPS unit excluding battery)	10 years (At a 30°C average ambient temperature. For reference purposes only.)				
EMC standard	—				
UPS classification according to IEC standard	VFI-SS-111		VFI-XX-111		
Separate options					
Rack support rails ⁽⁷⁾	5-minute backup	RM027-US (3U, 4 pairs), RM028-US (4U, 1 pair)		—	
	10-minute backup	RM028-US (4U, 5 pairs)		—	
Floor mounting brackets ⁽⁸⁾	FMA11NA00 (1 pc)				
Air filter kit ⁽⁹⁾	FLA11NA00-3U (3U, 4 pcs) or FLA11NA00-4U (4U, 4 pcs)				
Replacement battery pack model no.	BPA11N006A00M (3U, 8 pcs) or BPA11N009A00M (4U, 8 pcs)				

- (1) The rack mount models have model numbers ending in "RM" in place of wildcard characters.
- (2) AC input voltage range changes depending on the load level. The input voltage range is within -40% to +15% of the rated value at load levels ≤ 70%, and is within -20% to +15% of the rated value at load levels > 70%.
- (3) At the auto-sensing setting, the frequency synchronizing range can be set to ±1, 3, or 5%. At the auto-sensing setting, the input frequency range is within ±8% of the rated frequency. Also, for the inverter to start running, the input frequency must be within the set synchronizing frequency range. When fixed-frequency setting is selected, output frequency is fixed to either 50 Hz or 60 Hz regardless of input frequency. At the fixed-frequency setting, the input frequency range is 40 to 120 Hz.
- (4) Uninterrupted transfer to the bypass circuit is only possible when all of the following conditions are true: the frequency setting is set to automatic; input frequency is within the synchronizing range; input voltage is within the allowable range.

- (5) Communications:
- Dry contact signal: D-sub 15-pin female, with M3 fixing screws
 - PC port: USB Type C
 - Remote control: One-touch terminal block, compatible wire size: 24 to 16 AWG
- (6) Avoid use or storage in 30°C or higher temperatures for extended periods of time, or the battery life will shorten. If a UPS is to be stored for a long period, it will be necessary to recharge batteries once every two to six months.
- (7) Used for mounting the UPS on an EIA standard 19-inch rack. Prior to purchase, check that the rails are mountable to your 19-inch rack.
- (8) Used to secure the UPS to the floor.
- (9) Front side air intake filter to prevent dust ingress.
- Note 1: Output power is supplied from the inverter at start-up. (Inverter start-up type)
Note 2: The Instruction Manuals included with these models are in Japanese.

Dimensions (Unit: mm)

Fig. 1 Model: **S-A11N502A005**

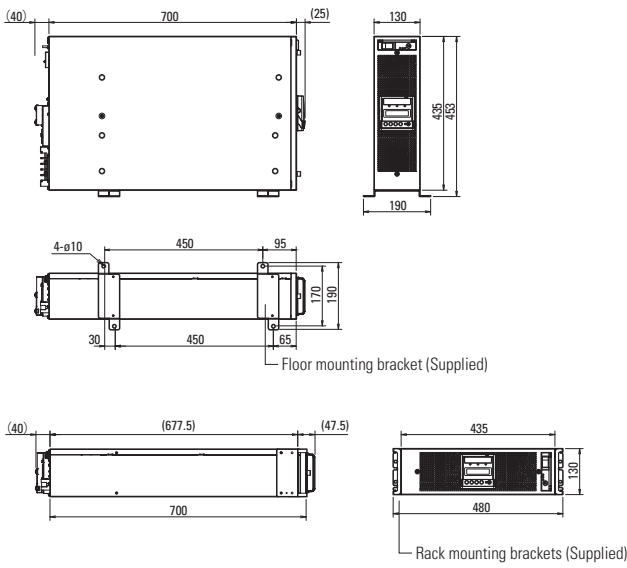

Model: **S-A11N502A005N**

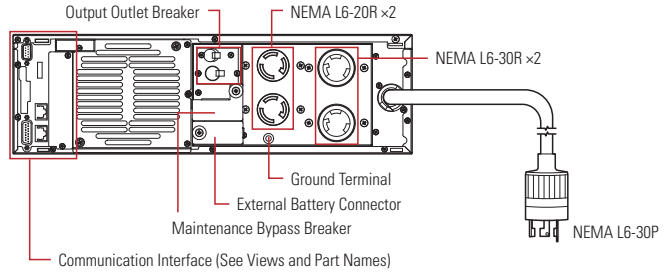

Model: **S-A11N502A005T**

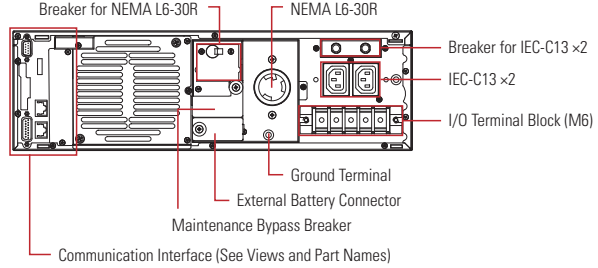
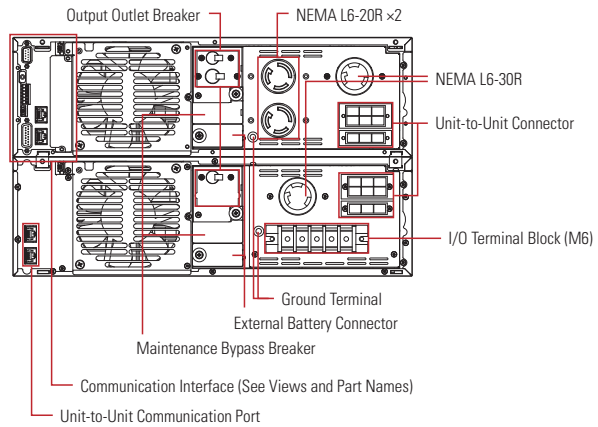
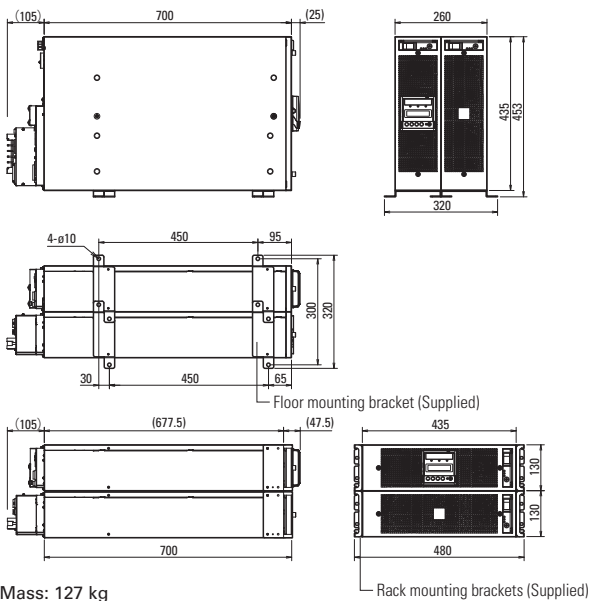

Fig. 2 Model: **S-A11N103A005T**



Dimensions (Unit: mm)

Fig. 3

Model: S-A11N502A010

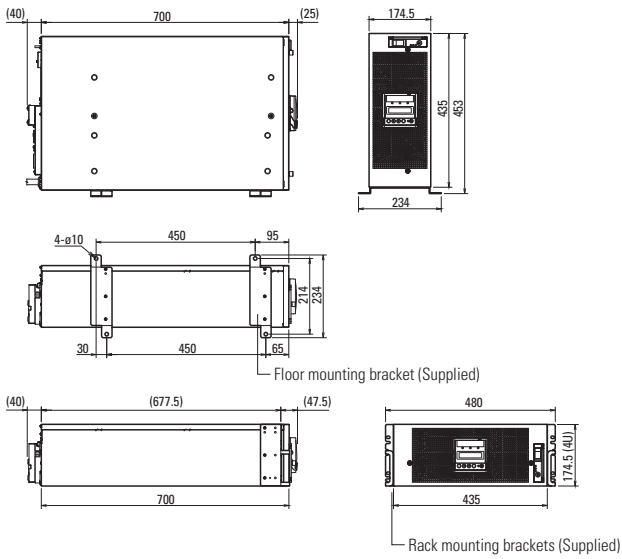

Mass: 80 kg

Paint color: Black (Munsell N1.5)

Model: S-A11N502A010N

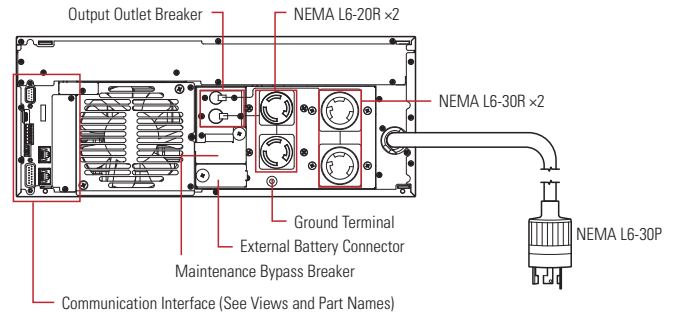

Model: S-A11N502A010T

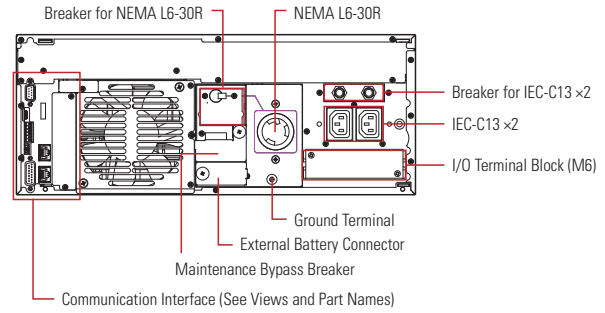

Dimensions (Unit: mm)

Fig. 4

Model: S-A11N502A005S2

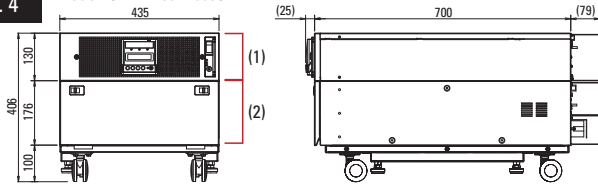

Mass: 110 kg

Model: S-A11N502A005S2RM

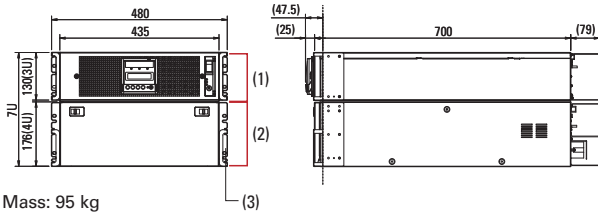

Mass: 95 kg

Fig. 5

Model: S-A11N103A005S2

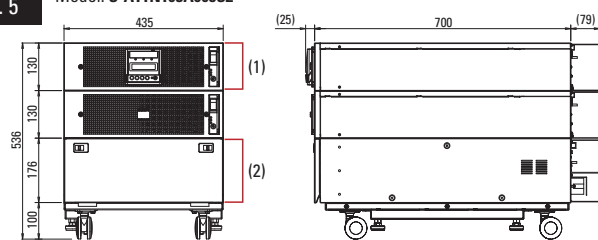

Mass: 170 kg

Model: S-A11N103A005S2RM

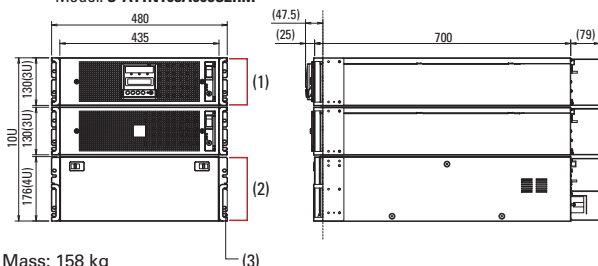

Mass: 158 kg

Fig. 6

Model: S-A11N153A005S2

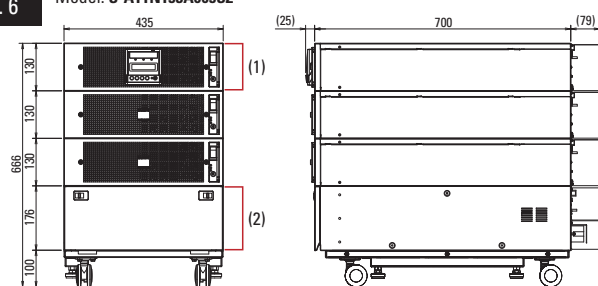

Mass: 230 kg

Model: S-A11N153A005S2RM

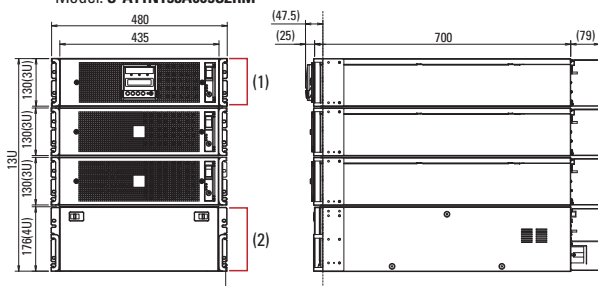

Mass: 221 kg

(1) UPS Unit - Rear View

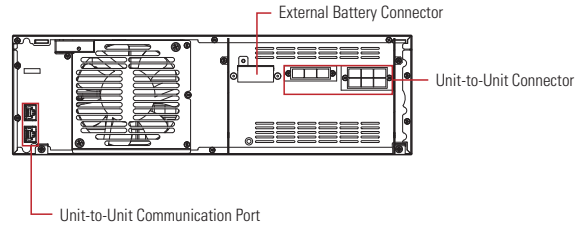

(2) PDU - Front Interior View

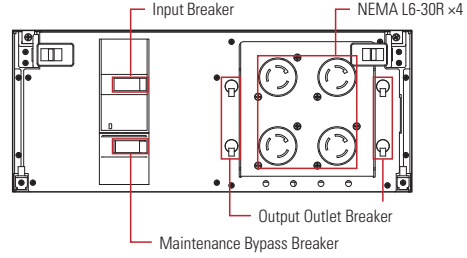

(2) PDU - Rear View

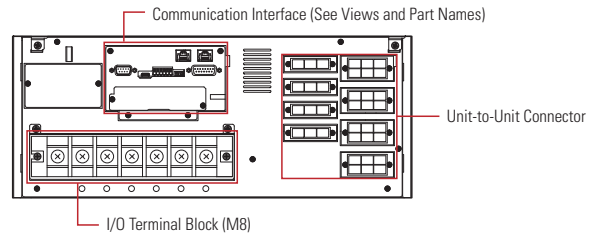

(3) Rack mounting brackets (Supplied)

Fig. 7

Model: S-A11N203A005S2

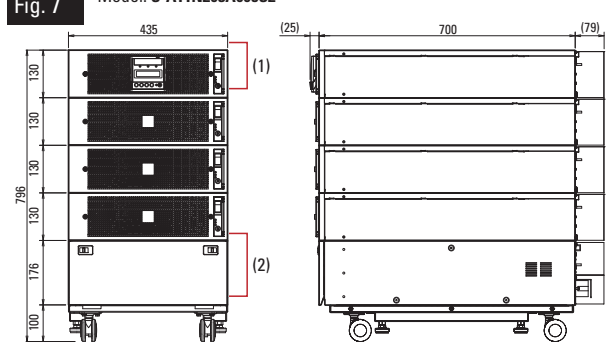

Mass: 290 kg

Model: S-A11N203A005S2RM

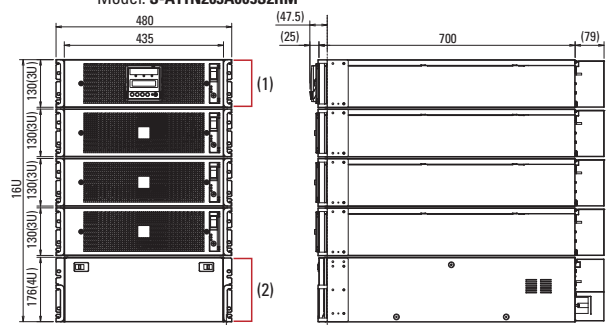

Mass: 284 kg

Dimensions (Unit: mm)

Fig. 8

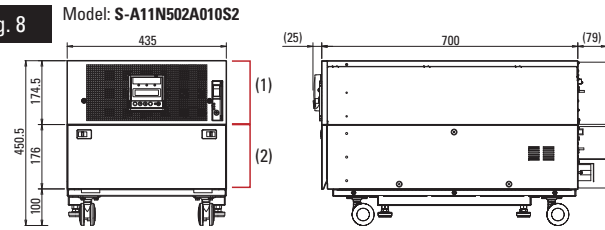

Mass: 130 kg

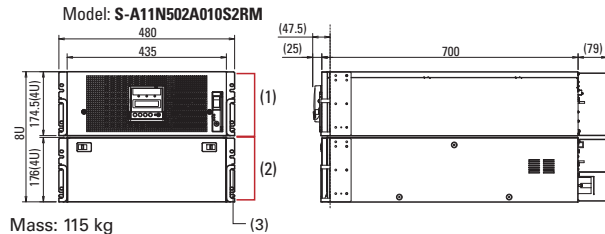

Mass: 115 kg

Fig. 9

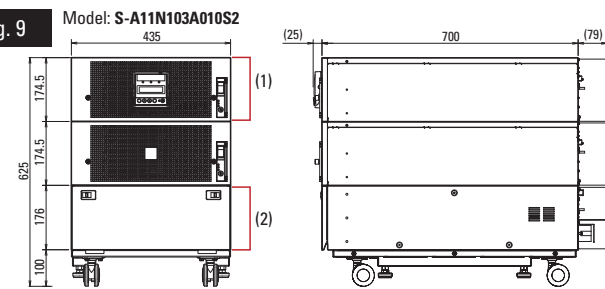

Mass: 210 kg

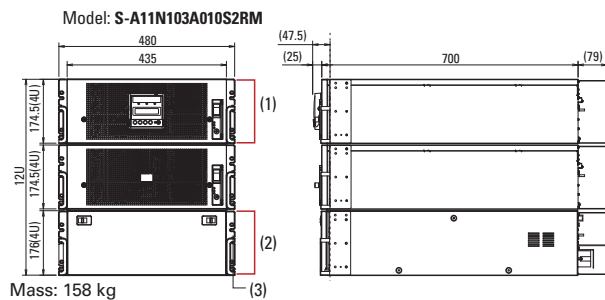

Mass: 158 kg

Fig. 10

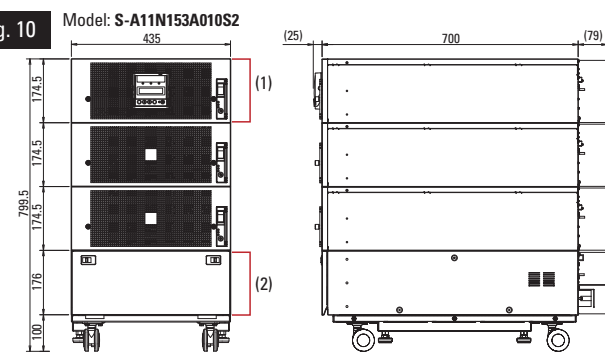

Mass: 290 kg

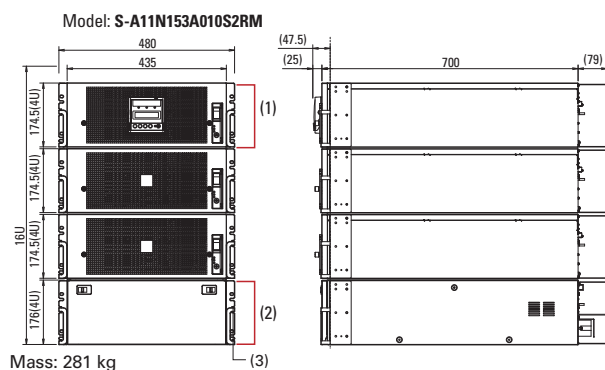

Mass: 281 kg

(1) UPS Unit - Rear View

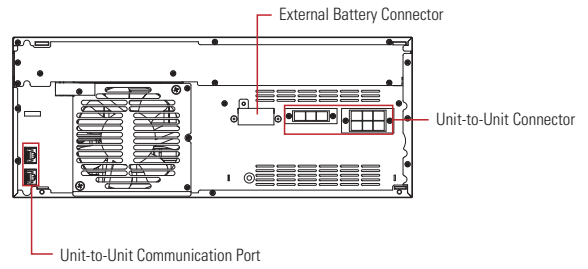

(2) PDU - Front Interior View

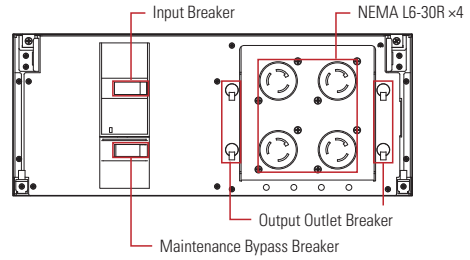

(2) PDU - Rear View

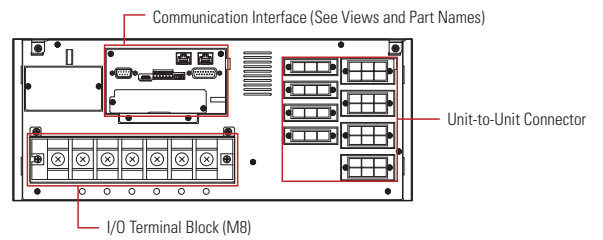

(3) Rack mounting brackets (Supplied)

Fig. 11

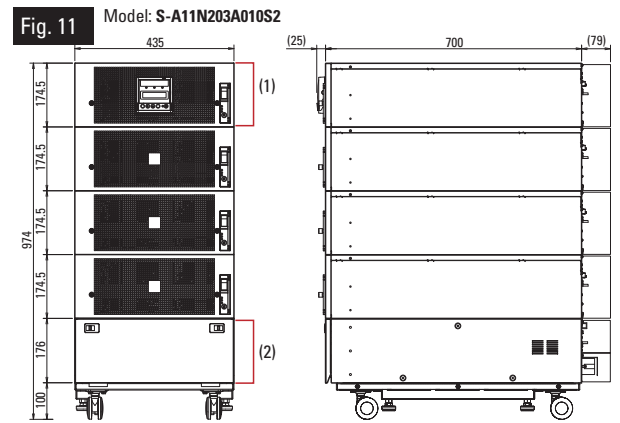

Mass: 370 kg

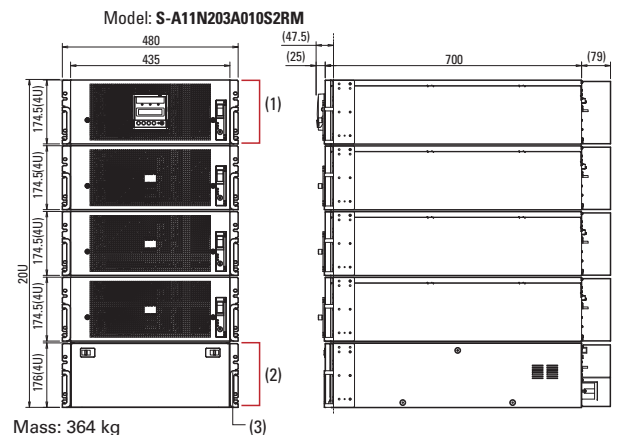

Mass: 364 kg

Dimensions (Unit: mm)

Fig. 12 Model: S-A11N502A005W1

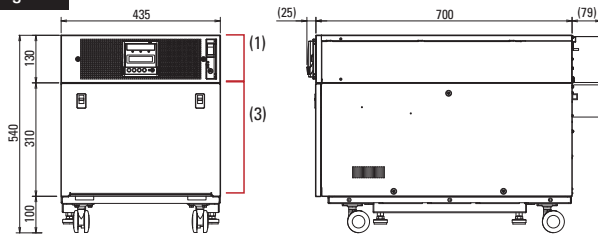

Mass: 195 kg

Fig. 13 Model: S-A11N502A010W1

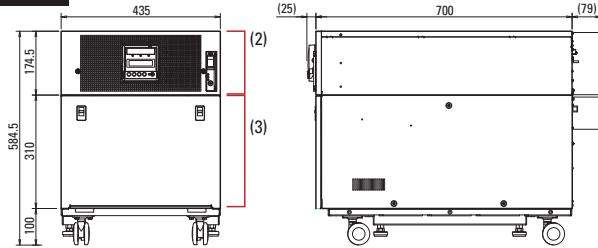

Mass: 215 kg

Fig. 14 Model: S-A11N103A005W1

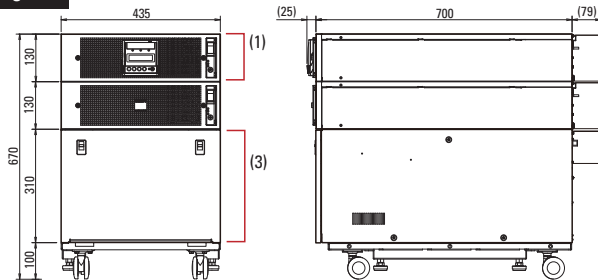

Mass: 300 kg

Fig. 15 Model: S-A11N103A010W1

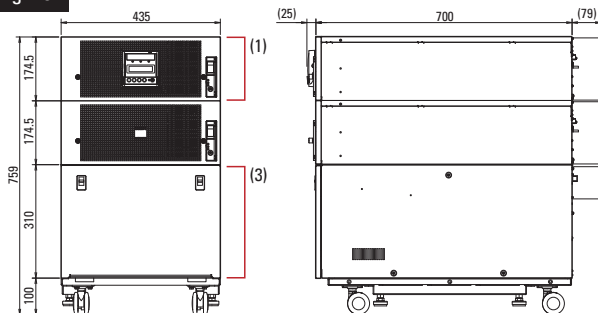

Mass: 340 kg

Paint color: Black (Munsell N1.5)

(1) UPS Unit (3U) - Rear View

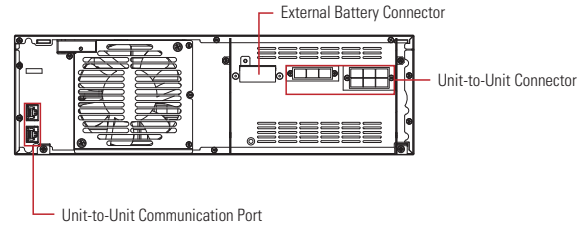

(2) UPS Unit (4U) - Rear View

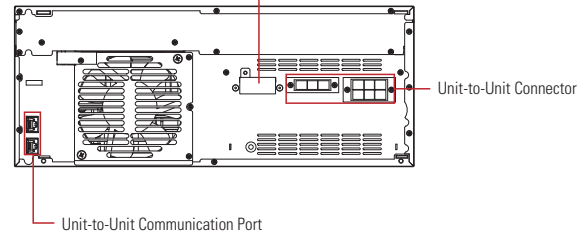

(3) PDU - Front Interior View

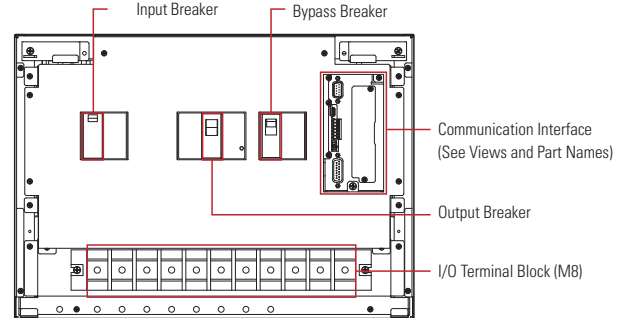

(3) PDU - Rear View

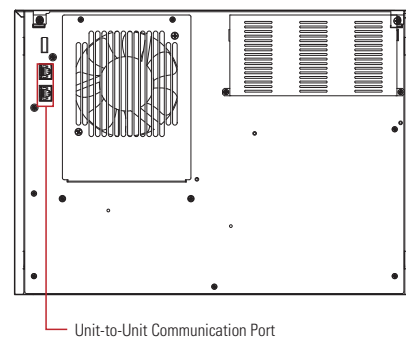

Dimensions (Unit: mm)

Fig. 16 Model: S-A11N502A005W2

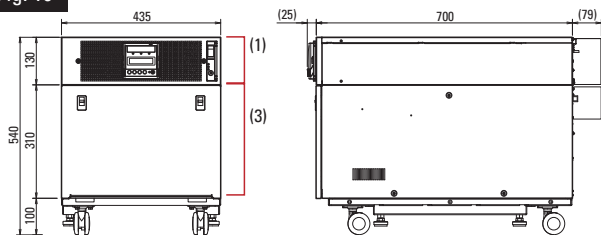

Mass: 170 kg

Fig. 17 Model: S-A11N502A010W2

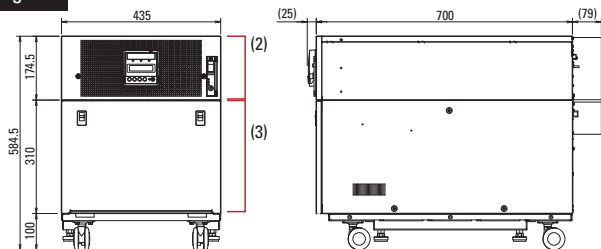

Mass: 190 kg

Fig. 18 Model: S-A11N103A005W2

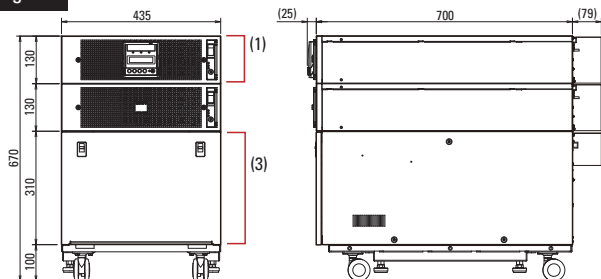

Mass: 255 kg

Fig. 19 Model: S-A11N103A010W2

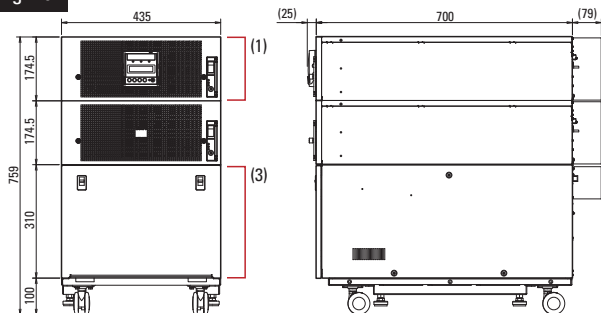

Mass: 295 kg

Paint color: Black (Munsell N1.5)

(1) UPS Unit (3U) - Rear View

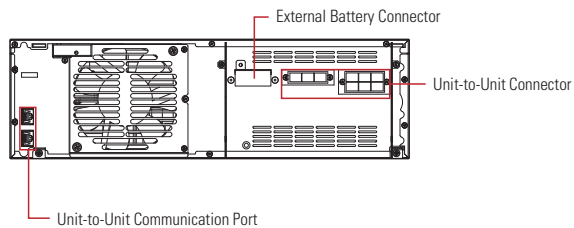

(2) UPS Unit (4U) - Rear View

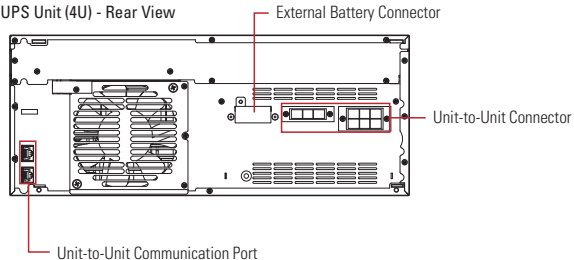

(3) PDU - Front Interior View

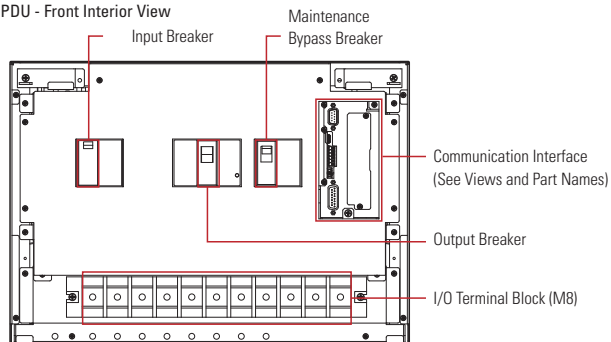

(3) PDU - Rear View

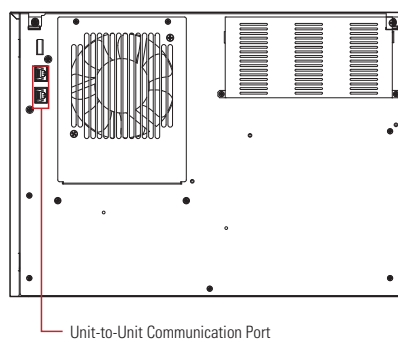

Dimensions (Unit: mm)

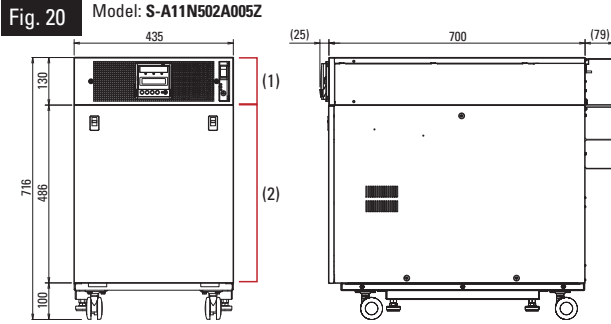

Mass: 270 kg

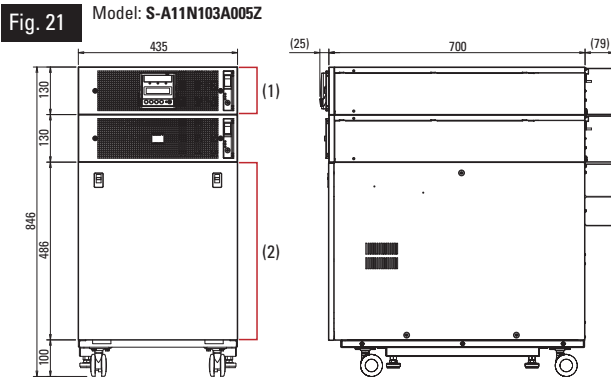

Mass: 330 kg

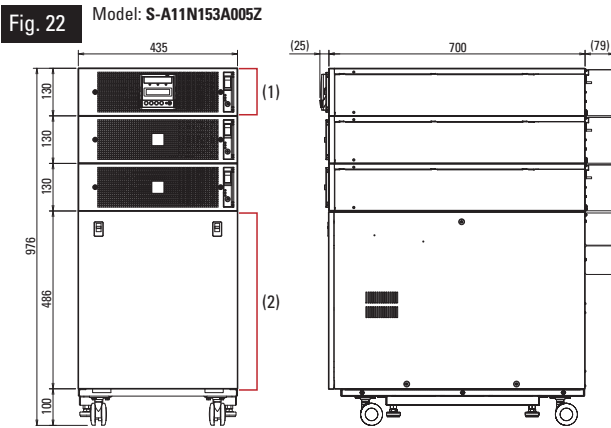

Mass: 390 kg

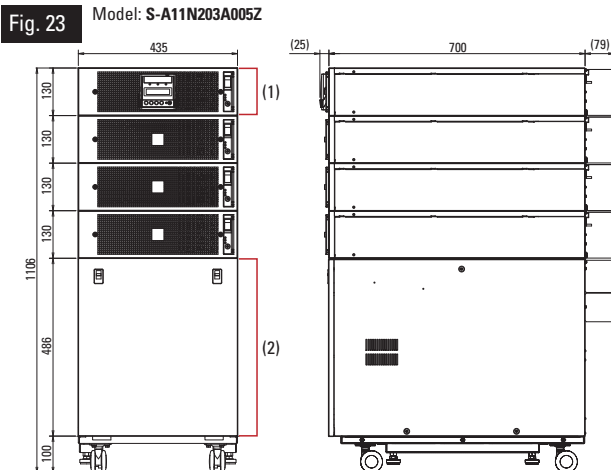

Mass: 450 kg

(1) UPS Unit - Rear View

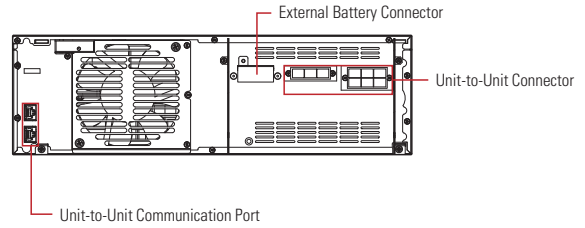

(2) PDU - Front Interior View

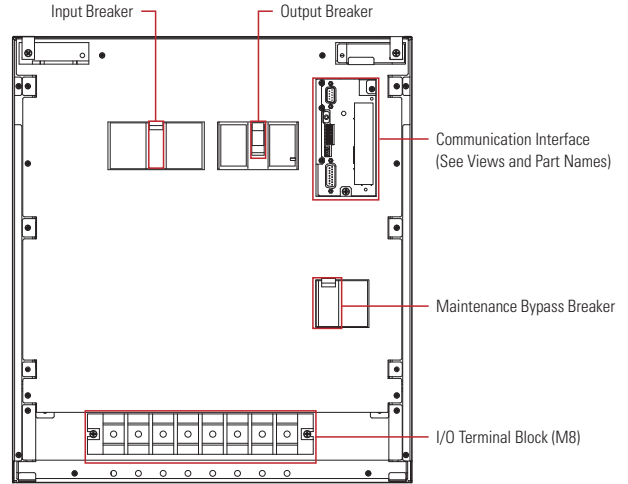

(2) PDU - Rear View

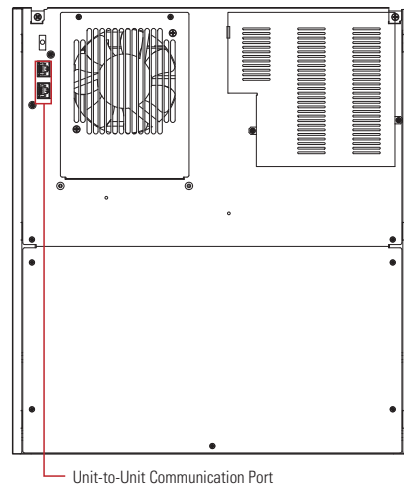

Paint color: Black (Munsell N1.5)

Dimensions (Unit: mm)

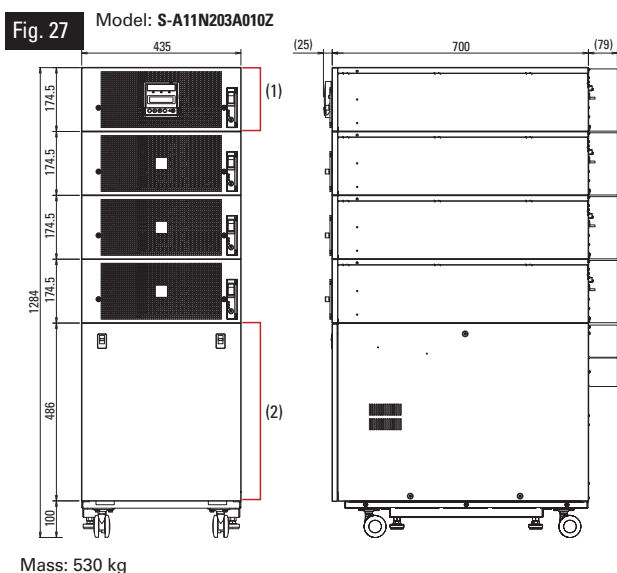
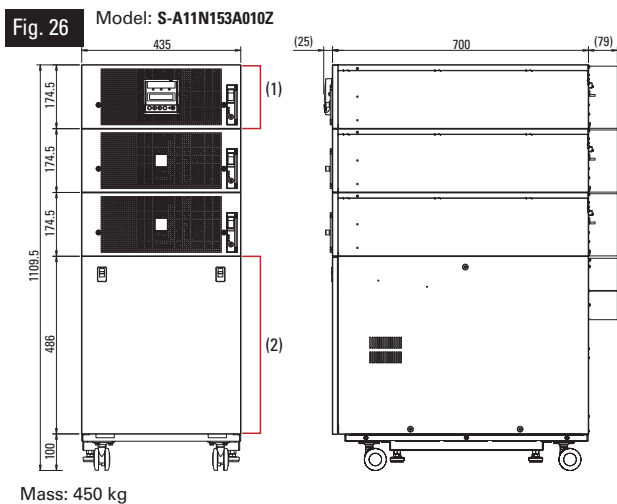
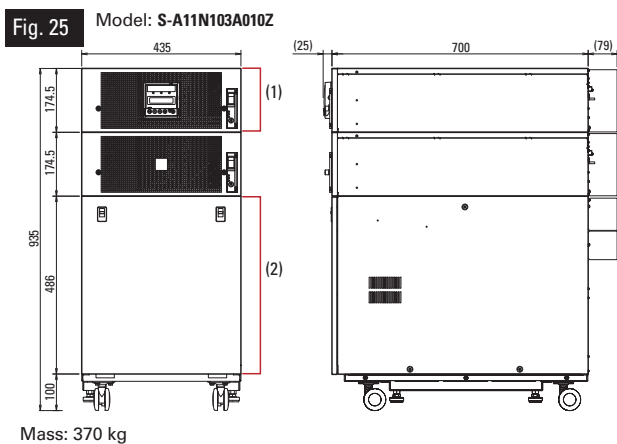
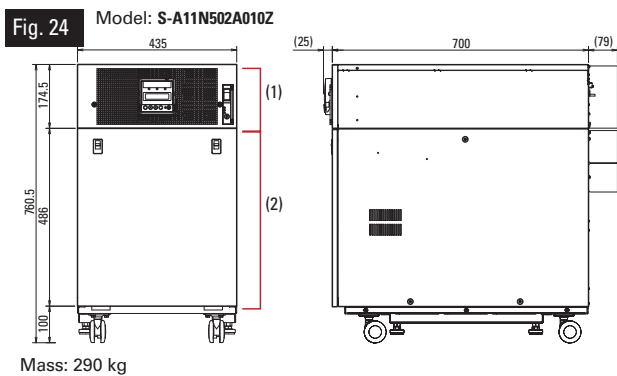

(1) UPS Unit - Rear View

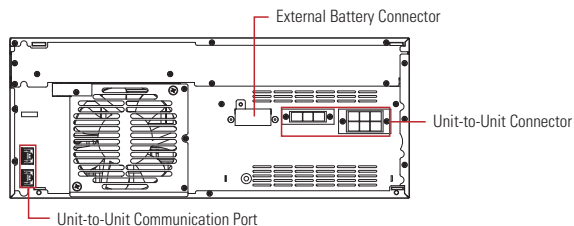

(2) PDU - Front Interior View

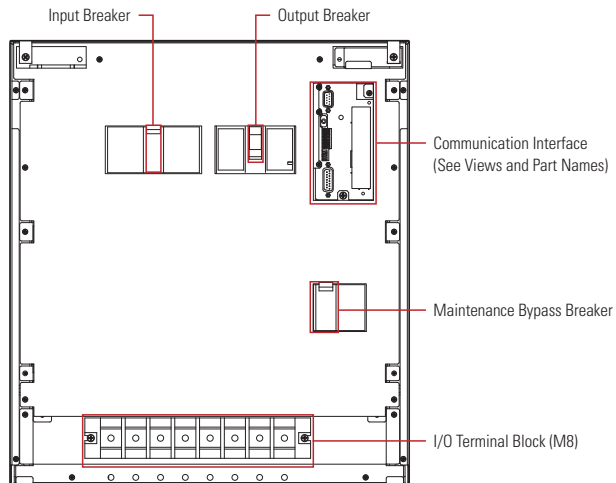

(2) PDU - Rear View

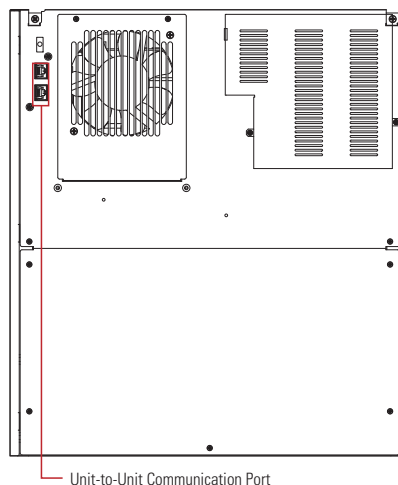

Dimensions (Unit: mm)

Output capacity **5 kVA**

Battery backup time **30 min**

Order no.	S-A11N502A030T	S-A11N502A030N	S-A11N502A030S2	S-A11N502A030W1	S-A11N502A030W2	S-A11N502A030Z
Input voltage	200 V			100/200 V		200 V
Output voltage	200 V			100 V or 100/200 V		100 V or 100/200 V
Battery	Quantity	16 pcs (12 V per battery)	16 pcs (12 V per battery)	16 pcs (12 V per battery)	16 pcs (12 V per battery)	16 pcs (12 V per battery)
	Total capacity [Wh]	5376	5376	5376	5376	5376
Dimensions		Fig. 28 (Fig. 1 + Fig. 73)	Fig. 28 (Fig. 1 + Fig. 73)	Fig. 29 (Fig. 4 + Fig. 73)	Fig. 30 (Fig. 12 + Fig. 73)	Fig. 30 (Fig. 16 + Fig. 73)
	W	440+(100)+130	440+(100)+130	440+(100)+435	440+(200)+435	440+(200)+435
	D ⁽¹⁾	700+(25)+(40)	700+(25)+(40)	700+(25)+(79)	700+(25)+(79)	700+(25)+(79)
	H	544	544	544	544	716
Mass ⁽²⁾	243 kg	243 kg	290 kg	375 kg	350 kg	450 kg

Battery backup time **60 min**

Order no.	S-A11N502A060T	S-A11N502A060N	S-A11N502A060S2	S-A11N502A060W1	S-A11N502A060W2	S-A11N502A060Z
Input voltage	200 V			100/200 V		200 V
Output voltage	200 V			100 V or 100/200 V		100 V or 100/200 V
Battery	Quantity	16 pcs (12 V per battery)	16 pcs (12 V per battery)	16 pcs (12 V per battery)	16 pcs (12 V per battery)	16 pcs (12 V per battery)
	Total capacity [Wh]	8448	8448	8448	8448	8448
Dimensions		Fig. 28 (Fig. 1 + Fig. 74)	Fig. 28 (Fig. 1 + Fig. 74)	Fig. 29 (Fig. 4 + Fig. 74)	Fig. 30 (Fig. 12 + Fig. 74)	Fig. 31 (Fig. 20 + Fig. 74)
	W	440+(100)+130	440+(100)+130	440+(100)+435	440+(200)+435	440+(200)+435
	D ⁽¹⁾	870+(12)	870+(12)	870+(12)	870+(12)	870+(12)
	H	544	544	544	544	716
Mass ⁽²⁾	348 kg	348 kg	395 kg	480 kg	455 kg	555 kg

Fig. 28

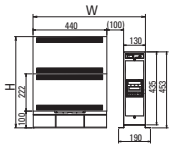

Fig. 29

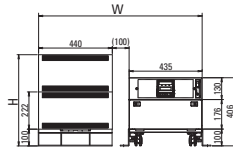

Fig. 30

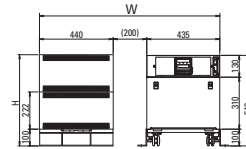
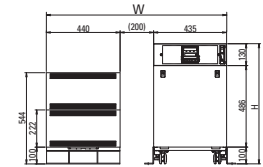

Fig. 31



Battery backup time **180 min**

Order no.	S-A11N502A180T	S-A11N502A180N	S-A11N502A180S2	S-A11N502A180W1	S-A11N502A180W2	S-A11N502A180Z
Input voltage	200 V			100/200 V		200 V
Output voltage	200 V			100 V or 100/200 V		100 V or 100/200 V
Battery	Quantity	32 pcs (12 V per battery)	32 pcs (12 V per battery)	32 pcs (12 V per battery)	32 pcs (12 V per battery)	32 pcs (12 V per battery)
	Total capacity [Wh]	16896	16896	16896	16896	16896
Dimensions		Fig. 32 (Fig. 1 + Fig. 76)	Fig. 32 (Fig. 1 + Fig. 76)	Fig. 33 (Fig. 4 + Fig. 76)	Fig. 34 (Fig. 12 + Fig. 76)	Fig. 35 (Fig. 20 + Fig. 76)
	W	440+(100)+130	440+(100)+130	440+(100)+435	440+(200)+435	440+(200)+435
	D ⁽¹⁾	870+(12)	870+(12)	870+(12)	870+(12)	870+(12)
	H	988	988	988	988	988
Mass ⁽²⁾	648 kg	648 kg	695 kg	780 kg	755 kg	855 kg

Fig. 32

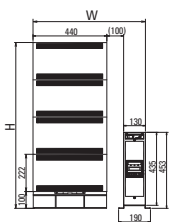

Fig. 33

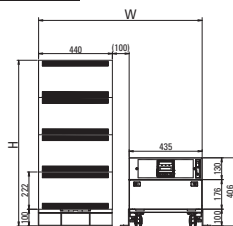

Fig. 34

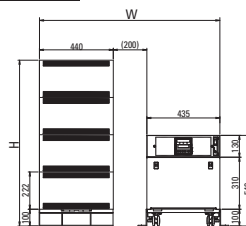
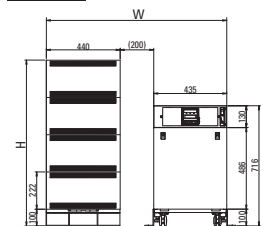

Fig. 35



(1) The sum of the depths of: a UPS unit (or PDU), cable cover, terminal block, and protrusions

(2) The sum of the masses of: a UPS unit, PDU, and battery

Paint color: Black (Munsell N1.5)

Dimensions (Unit: mm)

Output capacity **10 kVA**

Battery backup time **30 min**

Order no.	S-A11N103A030T	S-A11N103A030S2	S-A11N103A030W1	S-A11N103A030W2	S-A11N103A030Z	
Input voltage	200 V		100/200 V	200 V		
Output voltage	200 V		100 V or 100/200 V	100 V or 100/200 V		
Battery	Quantity	32 pcs (12 V per battery)	32 pcs (12 V per battery)	32 pcs (12 V per battery)	32 pcs (12 V per battery)	
	Total capacity [Wh]	10752	10752	10752	10752	
Dimensions		Fig. 36 (Fig. 2 + Fig. 75)	Fig. 37 (Fig. 5 + Fig. 75)	Fig. 38 (Fig. 14 + Fig. 75)	Fig. 38 (Fig. 18 + Fig. 75)	
	W	440+(100)+130×2	440+(100)+435	440+(200)+435	440+(200)+435	440+(200)+435
	D ⁽¹⁾	700+(25)+(105)	700+(25)+(79)	700+(25)+(79)	700+(25)+(79)	700+(25)+(79)
	H	988	988	988	988	988
Mass ⁽²⁾	472 kg	515 kg	645 kg	600 kg	675 kg	

Battery backup time **60 min**

Order no.	S-A11N103A060T	S-A11N103A060S2	S-A11N103A060W1	S-A11N103A060W2	S-A11N103A060Z	
Input voltage	200 V		100/200 V	200 V		
Output voltage	200 V		100 V or 100/200 V	100 V or 100/200 V		
Battery	Quantity	32 pcs (12 V per battery)	32 pcs (12 V per battery)	32 pcs (12 V per battery)	32 pcs (12 V per battery)	
	Total capacity [Wh]	16896	16896	16896	16896	16896
Dimensions		Fig. 36 (Fig. 2 + Fig. 76)	Fig. 37 (Fig. 5 + Fig. 76)	Fig. 38 (Fig. 14 + Fig. 76)	Fig. 38 (Fig. 18 + Fig. 76)	Fig. 39 (Fig. 21 + Fig. 76)
	W	440+(100)+130×2	400+(100)+435	440+(200)+435	440+(200)+435	440+(200)+435
	D ⁽¹⁾	870+(12)	870+(12)	870+(12)	870+(12)	870+(12)
	H	988	988	988	988	988
Mass ⁽²⁾	677 kg	720 kg	850 kg	805 kg	880 kg	

Fig. 36

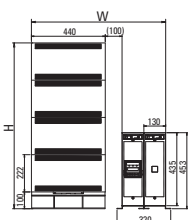

Fig. 37

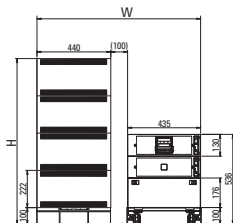

Fig. 38

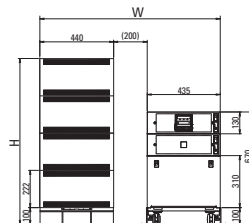
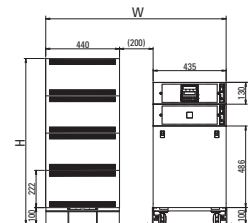

Fig. 39



Battery backup time **180 min**

Order no.	S-A11N103A180T	S-A11N103A180S2	S-A11N103A180W1	S-A11N103A180W2	S-A11N103A180Z
Input voltage	200 V		100/200 V	200 V	
Output voltage	200 V		100 V or 100/200 V	100 V or 100/200 V	
Battery	Quantity	64 pcs (12 V per battery)	64 pcs (12 V per battery)	64 pcs (12 V per battery)	64 pcs (12 V per battery)
	Total capacity [Wh]	33792	33792	33792	33792
Dimensions		Fig. 40 (Fig. 2 + Fig. 76 ×2)	Fig. 41 (Fig. 5 + Fig. 76 ×2)	Fig. 42 (Fig. 14 + Fig. 76 ×2)	Fig. 43 (Fig. 21 + Fig. 76 ×2)
	W	440×2+(100)+130×2	440×2+(100)+435	440×2+(200)+435	440×2+(200)+435
	D ⁽¹⁾	870+(12)	870+(12)	870+(12)	870+(12)
	H	988	988	988	988
Mass ⁽²⁾	1297 kg	1340 kg	1470 kg	1425 kg	1500 kg

Fig. 40

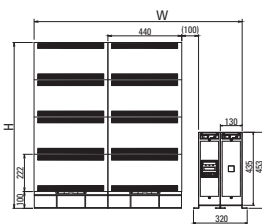

Fig. 41

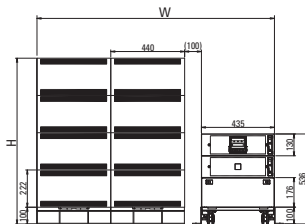

Fig. 42

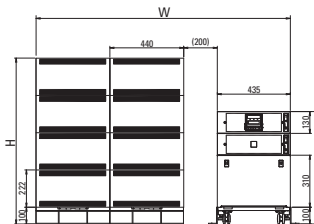
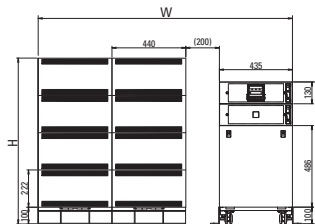

Fig. 43



(1) The sum of the depths of: a UPS unit (or PDU), cable cover, terminal block, and protrusions
 (2) The sum of the masses of: a UPS unit, PDU, and battery

Dimensions (Unit: mm)

Output capacity **15 kVA**

Battery backup time **30/60/180 min**

Order no.	S-A11N153A030S2	S-A11N153A030Z	S-A11N153A060S2	S-A11N153A060Z	S-A11N153A180S2	S-A11N153A180Z	
Input voltage	200 V						
Output voltage	200 V		100 V or 100/200 V		200 V		
Battery	Backup time	30 min		60 min		180 min	
	Quantity	48 pcs (12 V per battery)	48 pcs (12 V per battery)	48 pcs (12 V per battery)	48 pcs (12 V per battery)	96 pcs (12 V per battery)	
	Total capacity [Wh]	16128	16128	25344	25344	50688	
Dimensions	Fig. 44 (Fig. 6 + Fig. 73 + Fig. 75)	Fig. 45 (Fig. 22 + Fig. 73 + Fig. 75)	Fig. 46 (Fig. 6 + Fig. 74 + Fig. 76)	Fig. 47 (Fig. 22 + Fig. 74 + Fig. 76)	Fig. 48 (Fig. 6 + Fig. 76 × 3)	Fig. 49 (Fig. 22 + Fig. 76 × 3)	
	W	440×2+(100)+435	440×2+(100)+435	440×2+(100)+435	440×2+(200)+435	440×3+(100)+435	440×3+(200)+435
	D ⁽¹⁾	700+(25)+(79)	700+(25)+(79)	870+(12)	870+(12)	870+(12)	870+(12)
H	988	988	988	988	988	988	
Mass ⁽²⁾	755 kg	915 kg	1065 kg	1225 kg	1985 kg	2145 kg	

Fig. 44

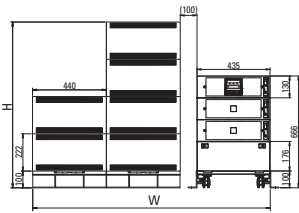

Fig. 45

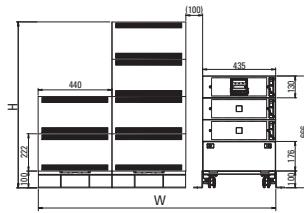

Fig. 46

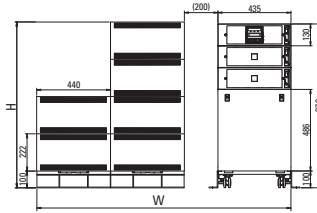

Fig. 47

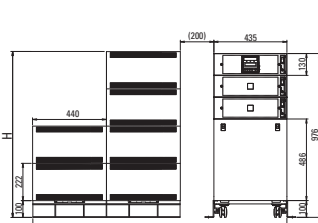

Fig. 48

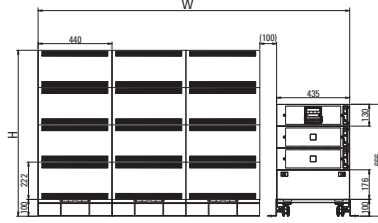
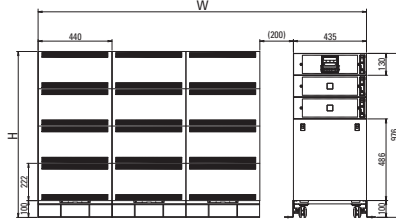

Fig. 49



Output capacity **20 kVA**

Battery backup time **30/60/180 min**

Order no.	S-A11N203A030S2	S-A11N203A030Z	S-A11N203A060S2	S-A11N203A060Z	S-A11N203A180S2	S-A11N203A180Z	
Input voltage	200 V						
Output voltage	200 V		100 V or 100/200 V		200 V		
Battery	Backup time	30 min		60 min		180 min	
	Quantity	64 pcs (12 V per battery)	64 pcs (12 V per battery)	64 pcs (12 V per battery)	64 pcs (12 V per battery)	128 pcs (12 V per battery)	
	Total capacity [Wh]	21504	21504	33792	33792	67584	
Dimensions	Fig. 50 (Fig. 7 + Fig. 75 × 2)	Fig. 51 (Fig. 23 + Fig. 75 × 2)	Fig. 52 (Fig. 7 + Fig. 76 × 2)	Fig. 53 (Fig. 23 + Fig. 76 × 2)	Fig. 54 (Fig. 7 + Fig. 76 × 4)	Fig. 55 (Fig. 23 + Fig. 76 × 4)	
	W	440×2+(100)+435	440×2+(200)+435	440×2+(100)+435	440×2+(200)+435	440×4+(100)+435	440×4+(200)+435
	D ⁽¹⁾	700+(25)+(79)	700+(25)+(79)	870+(12)	870+(12)	870+(12)	870+(12)
H	988	1106	988	1106	988	1106	
Mass ⁽²⁾	980 kg	1140 kg	1390 kg	1550 kg	2630 kg	2790 kg	

Fig. 50

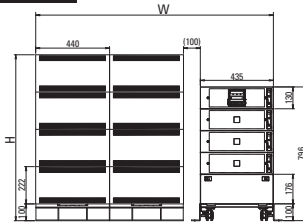

Fig. 51

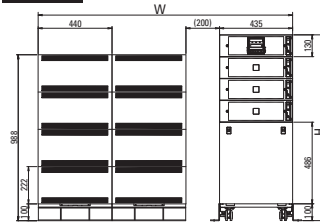

Fig. 52

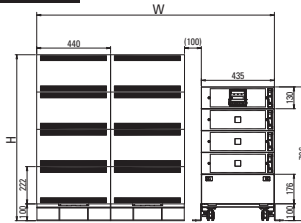

Fig. 53

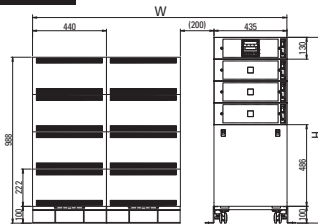

Fig. 54

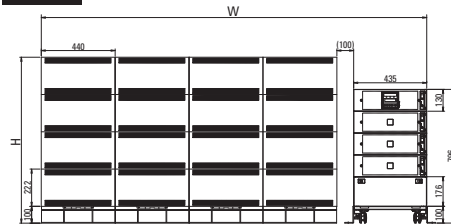
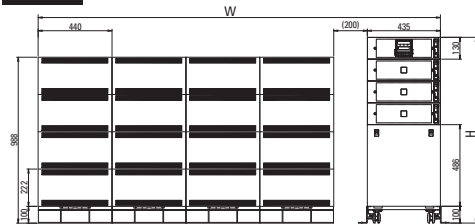

Fig. 55



(1)The sum of the depths of: a UPS unit (or PDU), cable cover, terminal block, and protrusions
 (2)The sum of the masses of: a UPS unit, PDU, and battery

Paint color: Black (Munsell N1.5)

Dimensions (Unit: mm)

Output capacity **5 kVA**

Battery backup time **15/25/35/45 min**

Free-standing (vertical) type

Order no.	S-A11N502A015T	S-A11N502A025T	S-A11N502A035T	S-A11N502A045T	
	S-A11N502A015N	S-A11N502A025N	S-A11N502A035N	S-A11N502A045N	
Input voltage	200 V				
Output voltage	200 V				
Battery	Backup time	15 min	25 min	35 min	45 min
	Quantity	32 pcs (12 V per battery)	48 pcs (12 V per battery)	64 pcs (12 V per battery)	80 pcs (12 V per battery)
	Total capacity [Wh]	2400	3600	4800	6000
Dimensions		Fig. 56 (Fig. 1 + Fig. 77)	Fig. 56 (Fig. 1 + Fig. 77)	Fig. 57 (Fig. 1 + Fig. 77 ×2)	Fig. 57 (Fig. 1 + Fig. 77 ×2)
	W	130×2	130×2	130×3	130×3
	D ⁽¹⁾	700+(25)+(79)	700+(25)+(79)	700+(25)+(79)	700+(25)+(79)
	H	453	453	453	453
Mass ⁽²⁾	112 kg	147 kg	196 kg	231 kg	

Fig. 56

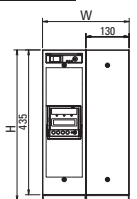
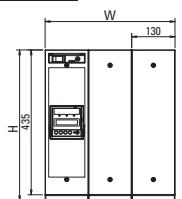

Fig. 57



Output capacity **10 kVA**

Battery backup time **15/25/35 min**

Free-standing (vertical) type

Order no.	S-A11N103A015T	S-A11N103A025T	S-A11N103A035T	
Input voltage	200 V			
Output voltage	200 V			
Battery	Backup time	15 min	25 min	35 min
	Quantity	64 pcs (12 V per battery)	96 pcs (12 V per battery)	128 pcs (12 V per battery)
	Total capacity [Wh]	4800	7200	9600
Dimensions		Fig. 58 (Fig. 2 + Fig. 77)	Fig. 59 (Fig. 2 + Fig. 77 ×2)	Fig. 60 (Fig. 2 + Fig. 77 ×4)
	W	130×3	130×4	130×6
	D ⁽¹⁾	700+(25)+(105)	700+(25)+(105)	700+(25)+(105)
	H	453	453	453
Mass ⁽²⁾	211 kg	295 kg	393 kg	

Fig. 58

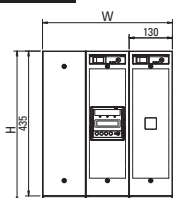

Fig. 59

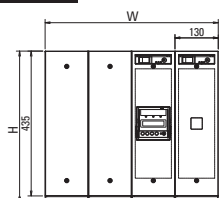
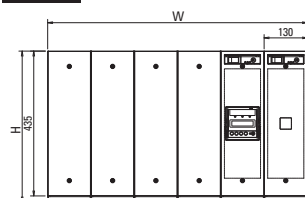

Fig. 60



(1) The sum of the depths of: a UPS unit (or PDU), cable cover, terminal block, and protrusions
 (2) The sum of the masses of: a UPS unit, PDU, and battery

Dimensions (Unit: mm)

Output capacity **5 kVA** Battery backup time **15/25/35/45 min** Rack mount type

Order no.	S-A11N502A015TRM	S-A11N502A025TRM	S-A11N502A035TRM	S-A11N502A045TRM	
	S-A11N502A015NRM	S-A11N502A025NRM	S-A11N502A035NRM	S-A11N502A045NRM	
Input voltage	200 V				
Output voltage	200 V				
Battery	Backup time	15 min	25 min	35 min	45 min
	Quantity	32 pcs (12 V per battery)	48 pcs (12 V per battery)	64 pcs (12 V per battery)	80 pcs (12 V per battery)
	Total capacity [Wh]	2400	3600	4800	6000
Dimensions		Fig. 61 (Fig. 1 + Fig. 77)	Fig. 61 (Fig. 1 + Fig. 77)	Fig. 62 (Fig. 1 + Fig. 77 ×2)	Fig. 62 (Fig. 1 + Fig. 77 ×2)
	W	435	435	435	435
	D ⁽¹⁾	700+(25)+(79)	700+(25)+(79)	700+(25)+(79)	700+(25)+(79)
	H	6U	6U	9U	9U
Mass ⁽²⁾	112 kg	147 kg	196 kg	231 kg	

Order no.	S-A11N502A015S2RM	S-A11N502A025S2RM	S-A11N502A035S2RM	S-A11N502A045S2RM	
Input voltage	200 V				
Output voltage	200 V				
Battery	Backup time	15 min	25 min	35 min	45 min
	Quantity	32 pcs (12 V per battery)	48 pcs (12 V per battery)	64 pcs (12 V per battery)	80 pcs (12 V per battery)
	Total capacity [Wh]	2400	3600	4800	6000
Dimensions		Fig. 63 (Fig. 4 + Fig. 77)	Fig. 63 (Fig. 4 + Fig. 77)	Fig. 64 (Fig. 4 + Fig. 77 ×2)	Fig. 64 (Fig. 4 + Fig. 77 ×2)
	W	435	435	435	435
	D ⁽¹⁾	700+(25)+(79)	700+(25)+(79)	700+(25)+(79)	700+(25)+(79)
	H	10 U	10 U	13 U	13 U
Mass ⁽²⁾	144 kg	179 kg	228 kg	263 kg	

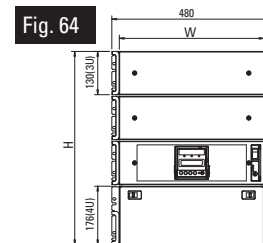
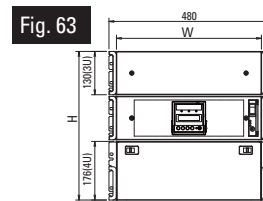
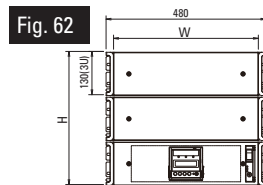
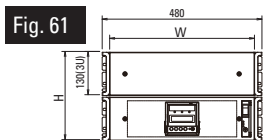

Output capacity **10 kVA** Battery backup time **15/25/35 min** Rack mount type

Order no.	S-A11N103A015TRM	S-A11N103A015S2RM	S-A11N103A025TRM	S-A11N103A025S2RM	S-A11N103A035TRM	S-A11N103A035S2RM	
Input voltage	200 V						
Output voltage	200 V						
Battery	Backup time	15 min	25 min	35 min	35 min		
	Quantity	64 pcs (12 V per battery)	64 pcs (12 V per battery)	96 pcs (12 V per battery)	96 pcs (12 V per battery)	128 pcs (12 V per battery)	128 pcs (12 V per battery)
	Total capacity [Wh]	4800	4800	7200	7200	9600	9600
Dimensions		Fig. 65 (Fig. 2 + Fig. 77)	Fig. 66 (Fig. 5 + Fig. 77)	Fig. 67 (Fig. 2 + Fig. 77 ×2)	Fig. 68 (Fig. 5 + Fig. 77 ×2)	Fig. 69 (Fig. 2 + Fig. 77 ×4)	Fig. 70 (Fig. 5 + Fig. 77 ×4)
	W	435	435	435	435	435	435
	D ⁽¹⁾	700+(105)+(25)	700+(25)+(79)	700+(105)+(25)	700+(25)+(79)	700+(105)+(25)	700+(25)+(79)
	H	9 U	13 U	12 U	16 U	18 U	22 U
Mass ⁽²⁾	211 kg	242 kg	295 kg	326 kg	393 kg	424 kg	

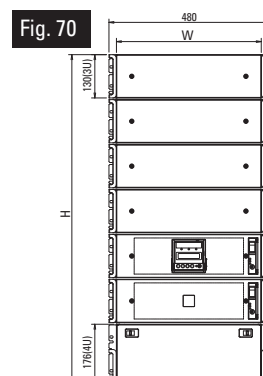
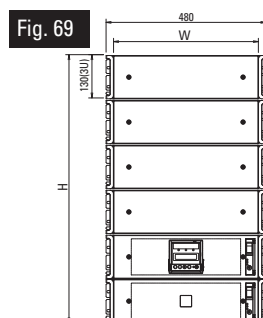
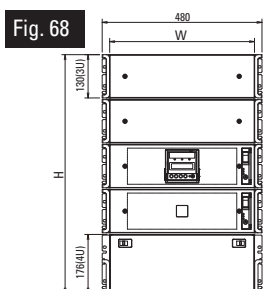
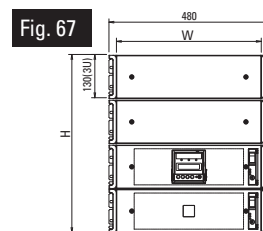
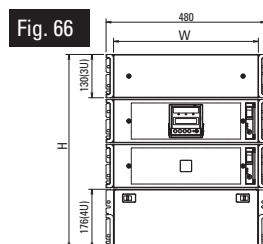
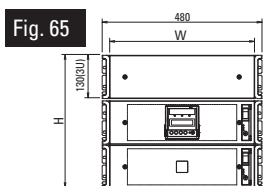

(1)The sum of the depths of: a UPS unit (or PDU), cable cover, terminal block, and protrusions
 (2)The sum of the masses of: a UPS unit, PDU, and battery

Dimensions (Unit: mm)

Output capacity 15 kVA **Battery backup time 15 min** **Rack mount type**

Order no.	S-A11N153A015S2RM	
Input voltage	200 V	
Output voltage	200 V	
Battery	Backup time	15 min
	Quantity	96 pcs (12 V per battery)
	Total capacity [Wh]	7200
Dimensions	Fig. 71 (Fig. 6 + Fig. 77 ×2)	
	W	435
	D ⁽¹⁾	700+(25)+(79)
	H	19U
Mass ⁽²⁾	354kg	

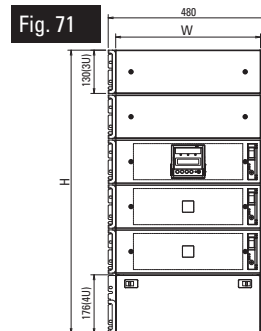

Output capacity 20 kVA **Battery backup time 15 min** **Rack mount type**

Order no.	S-A11N203A015S2RM	
Input voltage	200 V	
Output voltage	200 V	
Battery	Backup time	15 min
	Quantity	128 pcs (12 V per battery)
	Total capacity [Wh]	9600
Dimensions	Fig. 72 (Fig. 7 + Fig. 77 ×2)	
	W	435
	D ⁽¹⁾	700 +(25)+(79)
	H	22 U
Mass ⁽²⁾	452 kg	

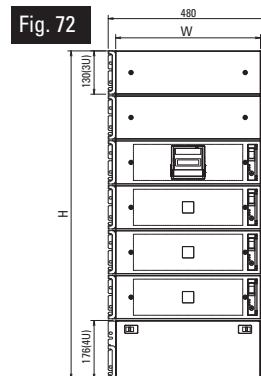

(1) The sum of the depths of: a UPS unit (or PDU), cable cover, terminal block, and protrusions
 (2) The sum of the masses of: a UPS unit, PDU, and battery

Paint color: Black (Munsell N1.5)

Battery Dimensions (Unit: mm)

Battery panel

Fig. 73

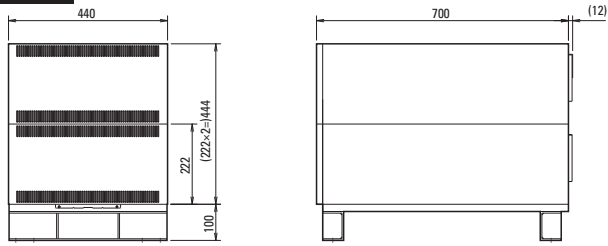

Fig. 74

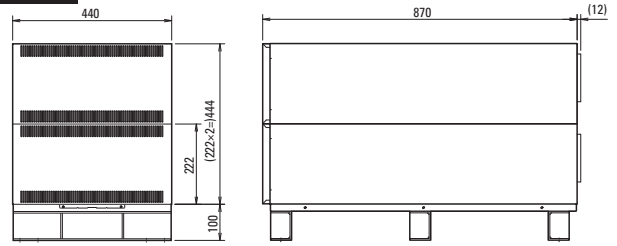

Fig. 75

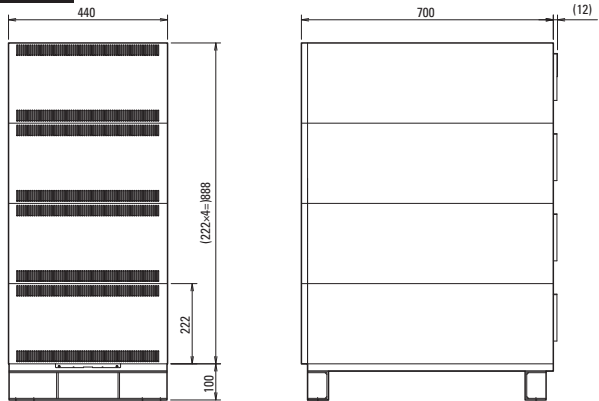
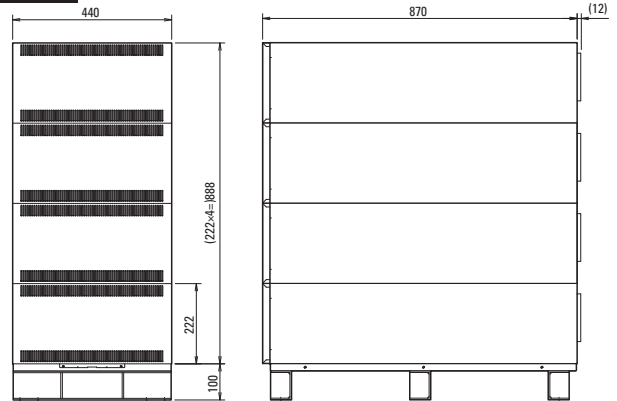
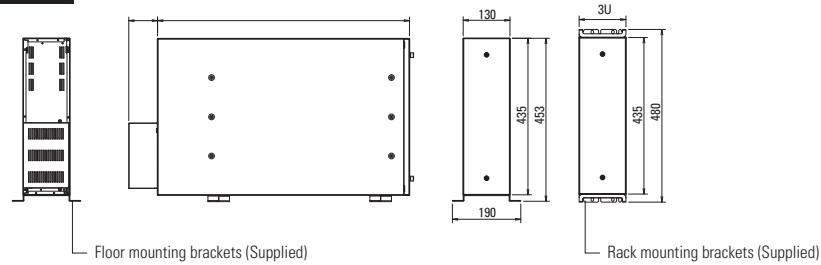

Fig. 76



Battery box

Fig. 77



Paint color: Black (Munsell N1.5)

Network Options

Items	Model no.	Description						
LAN interface card	PRLANIF031	When installed in the optional card slot, this card enables 24/7 monitoring of UPS operations and status, and sends email notifications to system administrators for quick actions via network in the event of a power failure. Combined with a temperature and humidity sensor (Model no.: 9CT1-T, extension cable: CARD-CBL007), this card can also monitor the ambient temperature and humidity. Multiple servers (up to 50) can be shut down through communication protocols such as SSH, Telnet, and REST API.						
SANUPS SOFTWARE for download	Windows version	PMS52□00DL⁽²⁾						
	Multi-OS version ⁽¹⁾	PMS53□00DL⁽²⁾						
		SANUPS SOFTWARE is used to shut down multiple servers (up to 50 servers including serial-connected servers) over a network from a single UPS-connected server with a USB cable. The software is not necessary when using the LAN interface card PRLANIF031. For the latest OS support information, refer to our website.						
		For bulk purchase of software licenses, append an appropriate -suffix to the model number as on the right.						
		<table border="0"> <tr> <td>-10</td> <td>(10 licenses)</td> </tr> <tr> <td>-50</td> <td>(50 licenses)</td> </tr> <tr> <td>-100</td> <td>(100 licenses)</td> </tr> </table>	-10	(10 licenses)	-50	(50 licenses)	-100	(100 licenses)
-10	(10 licenses)							
-50	(50 licenses)							
-100	(100 licenses)							

(1) Supports Windows, Unix, and Linux.

(2) The □'s denote revision characters.

Note: Option products have different operating temperature ranges from the UPS.

Dimensions (Unit: mm)

Rack support rails

Used for mounting the UPS on a standard EIA 19-inch rack. (A pair of left and right rails. The figures below are for the left one.)

RM027-US (3U)

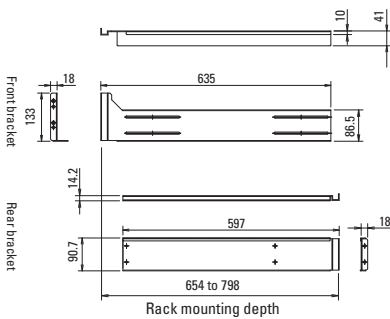

Mass: Approx. 2.6 kg (5.2 kg for the left and right pair)

RM028-US (4U)

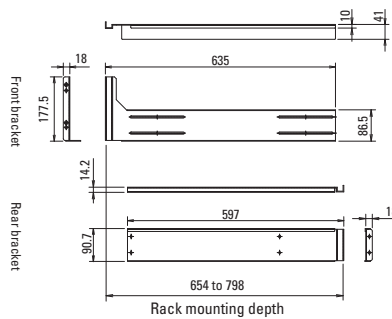

Mass: Approx. 2.7 kg (5.4 kg for the left and right pair)

Rack mounting brackets for securing a UPS in a rack come included with or installed to the UPS.

Floor mounting brackets

Used for mounting the UPS to the floor. (A pair of left and right rails. The figures below are common to both.)

FMA11NA00

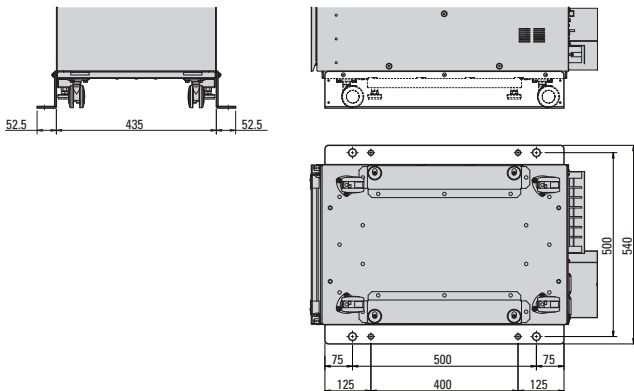

Mass: Approx. 3.5 kg (7 kg for the left and right pair)

Specifications

UL/CE certified models

Output capacity **5 kVA, 10 kVA**

Order no.		A11N502U0TM	A11N103U0TM	
UL-registered no. (Model)		A11N502U0T	A11N103U0T	
Rated output capacity (apparent power / active power)	Single-unit/Parallel operation (N config.)	5 kVA / 4.5 kW	10 kVA / 9 kW	
	Parallel redundant operation (N+1 config.)	—	5 kVA / 4.5 kW	
Technology	Topology	Double conversion online		
	Cooling system	Forced air cooling		
	Inverter	High-frequency PWM		
AC input	No. of phases/wires	Single-phase 2-wire		
	Rated voltage	200/208/220/230/240 V (Selectable. Factory setting: 200 V)		
	Voltage range ⁽¹⁾	Within -40% to +15% of rated voltage		
	Rated frequency	50/60 Hz (Auto-sensing or fixed-frequency mode selectable. ⁽²⁾ Factory setting: auto-sensing)		
	Required capacity	N config.	5.5 kVA or less	11 kVA or less
		N+1 config.	—	6.2 kVA or less
Input power factor	0.95 or greater (at rated input voltage, input voltage harmonic distortion < 1%)			
AC output	No. of phases/wires	Single-phase 2-wire		
	Rated voltage	200/208/220/230/240 V (Same as input voltage)		
	Voltage regulation	Within ±2% of rated voltage		
	Rated frequency	50/60 Hz (Same as input frequency)		
	Frequency regulation ⁽²⁾	In grid operation	Within ±1/3/5% of rated frequency (Factory setting: ±3%)	
		At free run (asynchronous)	Within ±0.5% of rated frequency	
	Voltage waveform	Sinusoidal		
	Voltage harmonic distortion	At linear load	3% or less (At rated output)	
		At rectifier load	7% or less (At rated output)	
	Load power factor	Rated	0.9 lagging (Variation range: 0.7 lagging to 1.0)	
	Transient voltage fluctuation	Abrupt load change	Within ±5% of rated voltage (For 10↔100% abrupt change)	
		Loss/return of input power	Within ±5% of rated voltage	
		Abrupt input voltage change	Within ±5% of rated voltage (For ±10% abrupt change)	
	Overcurrent protection	N config.	110% or more (Automatic transfer to bypass circuit ⁽³⁾ if exceeded)	
		N+1 config.	—	220% or more (Automatic transfer to bypass circuit ⁽³⁾ if exceeded)
	Overload capability	Inverter	N config.	110% (for 1 min), 118% (instantly)
N+1 config.			—	
Bypass		N config.	200% (for 30 s), 800% (for 2 cycles)	
		N+1 config.	—	
Battery	Type	Small-sized valve-regulated lead-acid (VRLA) battery		
	Backup time	5 min (At 25°C ambient temperature and load power factor of 0.9, using new, fully charged batteries)		
	Quantity	16 pcs (12 V per battery)	32 pcs (12 V per battery)	
	Rated capacity	6 Ah per battery		
	Expected service life	5 years (At a 25°C average ambient temperature. For reference purposes only.)		
Acoustic noise (1 m from front of UPS, A-weighted)	Excluding start of charging	45 dB or less	50 dB or less	
	At start of charging	51 dB or less	53 dB or less	
Heat dissipation (at rated output after fully charged)		287 W	574 W	
Input leakage current		5 mA or less	18 mA or less	
I/O connector, wire gauge, etc. ⁽⁴⁾	Input connector	Field wiring connection	Field wiring connection	
	Input wire	8 mm ²	14 or 22 mm ²	
	Output connector	Field wiring connection	Field wiring connection	
	Output wire	8 mm ²	14 or 22 mm ²	
	Grounding wire	5.5 mm ²	14 or 22 mm ²	
	Input distribution board breaker capacity	50 A	100 A	
Operating environment	Temperature: 0 to +40°C, humidity: 10 to 90% RH (non-condensing)			
Storage environment ⁽⁵⁾	Temperature: -15 to +50°C, humidity: 10 to 90% RH (non-condensing)			
Expected service life (of the UPS unit excluding battery)	10 years (At a 30°C average ambient temperature. For reference purposes only.)			
EMC standard	EN 62040-2:2018 C2, EN 55032:2015, EN 55035:2017, FCC Part 15 Subpart B Class A, VCCI 32-1 Class A			
Safety standard	UL 1778 5th edition (E226092), CSA C22.2 No. 107.3-14 (3rd edition), CE marking (EN 62040-1:Ed. 2:2017)			
Separate options				
Rack support rails ⁽⁶⁾	RM027-US (1 pair)	RM027-US (2 pairs)		
Air filter kit ⁽⁷⁾	FLA11NA00 (1 pc)	FLA11NA00 (2 pcs)		

(1) AC input voltage range changes depending on the load level. The input voltage range is within -40% to +15% of the rated value at load levels ≤ 70%, or within -20% to +15% of the rated value at load levels > 70%.

(2) At the auto-sensing setting, the frequency synchronizing range can be set to ±1, ±3, or ±5%. At the auto-sensing setting, the input frequency range is within ±8% of the rated frequency. Also, for the inverter to start running, the input frequency must be within the set synchronizing frequency range. When fixed-frequency setting is selected, output frequency is fixed to either 50 Hz or 60 Hz regardless of input frequency. At the fixed-frequency setting, the input frequency range is 40 to 120 Hz.

(3) Uninterrupted transfer to bypass operation is only possible when all of the following conditions are true: the automatic frequency detection setting is selected, the input frequency is within the synchronizing range, and the input voltage is within the allowable range.

(4) Communications:
 a. Dry contact signal: D-sub 15-pin female, with M3 fixing screws
 b. PC port: USB Type C
 c. Remote control: One-touch terminal block, compatible wire size: 24 to 16 AWG

(5) Avoid use or storage in 30°C or higher temperatures for extended periods of time, or the battery life will shorten. If a UPS is to be stored for a long period, it will be necessary to recharge batteries once every two to six months.

(6) Used for mounting a UPS unit and battery unit on an EIA standard 19-inch rack. Prior to purchase, check that the rails are mountable to your 19-inch rack.

(7) A front side air intake filter for preventing dust ingress.
 Note: Output power is supplied from the inverter at start-up. (Inverter start-up type)

Dimensions (Unit: mm)

Model: **A11N502U0TM**

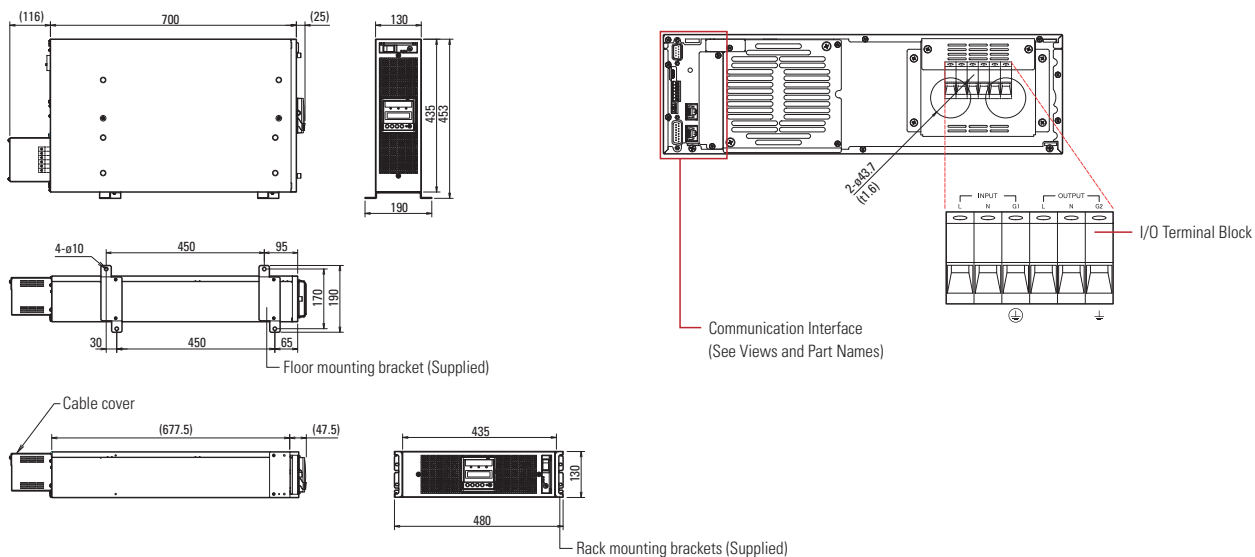

Mass: 63 kg

Model: **A11N103U0TM**

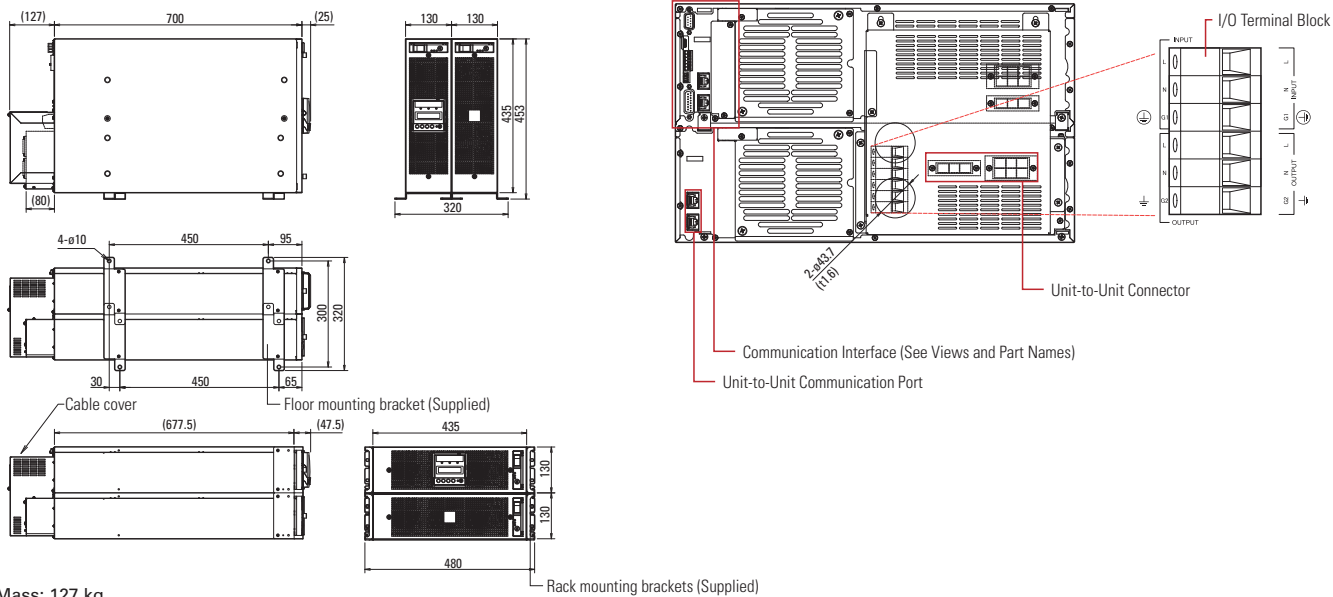

Mass: 127 kg

Paint color: Black (Munsell N1.5)

MEMO

MEMO

UPS warranty period

For warranty details, see the Warranty Card included with your UPS.

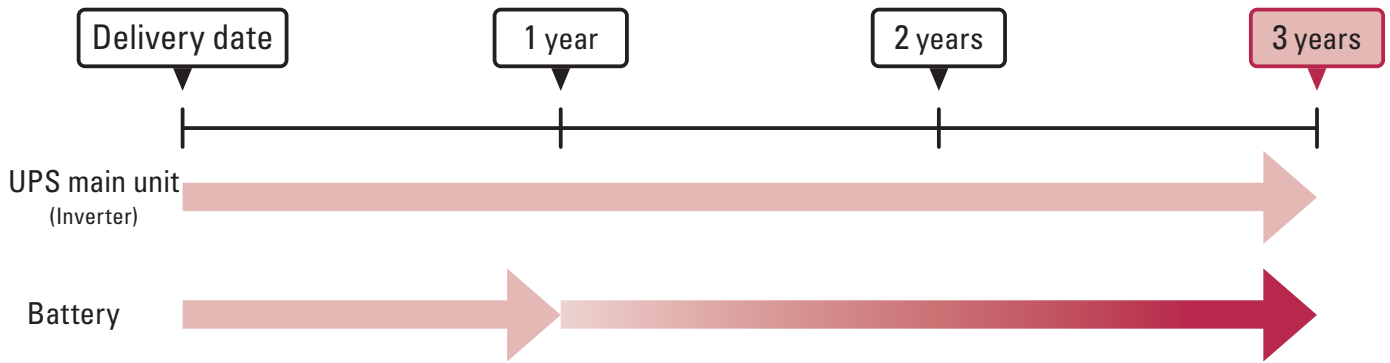

Battery warranty period is one year. It can be extended to three years by registering the UPS.

Note: This benefit is limited to users in Japan. Also, the battery replacement warranty does not cover a battery box or battery panel. See the Instruction Manual for replacing the battery box and battery panel.

Complete registration on our website:

<https://www.sanyodenki.com/>



■ Eco Products

Eco Products are eco-friendly products designed to reduce the environmental impact of the product and its packaging materials compared to conventional products on the market.

Our products are assessed over the product's life cycle against our own eco-design requirements including product size, weight, power consumption, and CO₂ emissions, and those meeting our standards and higher standards qualify as Eco Products and Eco Products Plus, respectively.

● Fire Service Law and Fire Prevention Ordinance in Japan

The Fire Prevention Ordinance regulates the total battery capacity of storage batteries, including lithium-ion batteries, that can be installed indoors. When installing UPSs indoors, check that the total battery capacity of a given location does not exceed 20 kWh. If exceeded, consult with your local fire department. Note that the UPSs cannot be used as an emergency power supply for firefighting equipment.

● Building Standard Law in Japan

The UPSs cannot be used as backup power for building facilities conforming to the disaster management requirements defined in the Building Standard Law.

Notes before Purchase

- Before installing, assembling, and using the products, please read Instruction Manual carefully and use them properly.
- When using the products in the following applications, consult with us in advance because special considerations are required for operation, maintenance, and management.
 - (a) Medical equipment that may have direct effects on human life or human body.
 - (b) Trains, elevators, and other machinery that can cause injury.
 - (c) Socially and publicly important computer systems.
 - (d) Other equipment that is related to safety of human life and that can have major impact on maintenance of public functions.
- For use in an environment where vibration is present, such as in a car or a ship, please consult with us in advance.
- Never attempt to disassemble or alter the products in any way.
- For installation and maintenance work of the products, please consult with us or properly licensed personnel.
- Please contact us concerning the disposal of used storage batteries supplied by SANYO DENKI.

● The products listed in this catalog fall into the category 16 of Appended Table 1 of the Export Trade Control Order. To export the products as an individual part or to export a device into which the products are assembled, the "Inform Requirements" and "Objective Requirements" that the Ministry of Economy, Trade and Industry of Japan established based on the "Catch-all Controls" must be studied for applicability. Accordingly, appropriate export formalities must be performed.

● SANYO DENKI will not be liable for any direct or indirect damages or loss, including but not limited to equipment downtime, missed power sales revenue, business interruptions, increased power purchases, resulting from the use of or inability to use our products or services.

● The products listed in this catalog are equipped with lithium-ion batteries. When transporting the products, do not transport by air. When transporting by sea, transport must be carried out according to the International Maritime Dangerous Goods (IMDG) Code. Also, depending on the country and region, there are cases where regulations are established independently, so please consult with the shipping company in advance.

For any inquiry or consultation, please contact a SANYO DENKI sales representative.

SANYO DENKI CO., LTD. 3-33-1 Minami-Otsuka, Toshima-ku, Tokyo 170-8451, Japan TEL: +81 3 5927 1020

<https://www.sanyodenki.com/>

The names of companies and/or their products specified in this document are the trade names, and/or trademarks and/or registered trademarks of such respective companies.

San Ace, SANUPS, and SANMOTION are registered trademarks of SANYO DENKI CO., LTD.

Specifications are subject to change without notice.

CATALOG No.P1054B003 '24.10